



Video for network engineers: What is relevant to you?



Thomas Kernen
Consulting Engineer
thkernen@cisco.com

Agenda

- Video networks 101
- Video requirements
- Architectural solutions
- Monitoring solutions
- Summary

Video networks 101



Video Service Providers

Mapping to Broadcast Industry

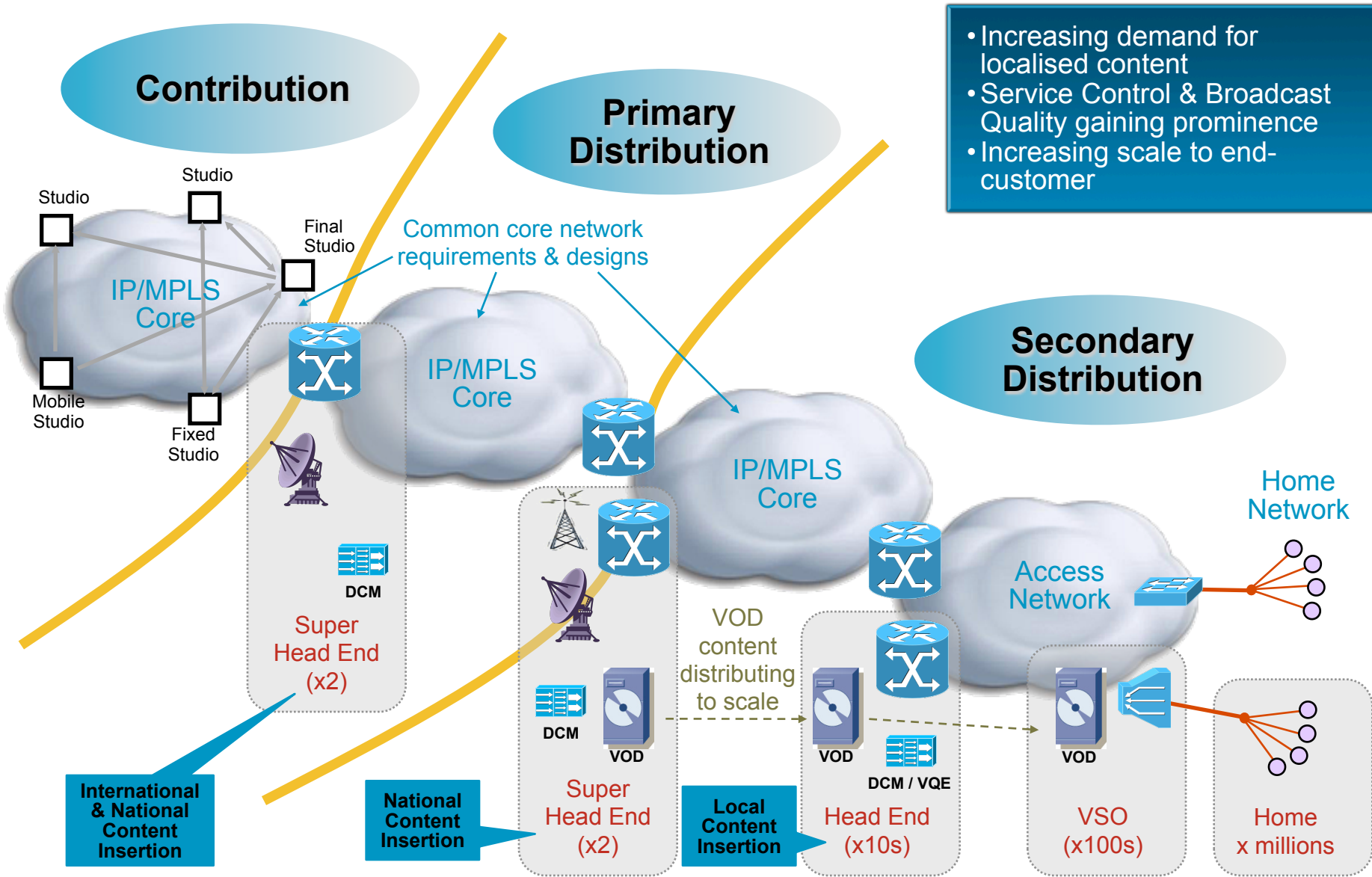

- Increasing demand for localised content
- Service Control & Broadcast Quality gaining prominence
- Increasing scale to end-customer

Basic IP network requirements

- No magic without the basics in place
- Multicast enabled infrastructure
 - SSM preferred vs. ASM. Less complex and more secure
- QoS
 - Queuing strategy, classification and DSCP markings
- Know your hardware do's and don'ts

Main video carriages

- Uncompressed Video:
 - SD: ITU BT.656 / SMPTE 259M (270 Mbps)
 - HD: SMPTE 292M (1.485 Gbps)
 - HD: SMPTE 372M / SMPTE 424M (2.970 Gbps)
- Frame by Frame compressed:
 - JPEG 2000 (50 - 200 Mbps)
 - DNxHD (SMPTE VC-3) (36 - 220 Mbps)
 - AVC-Intra (50 & 100 Mbps)
- Group of pictures compression:
 - MPEG-2 Video (4 - 60 Mbps)
 - H.264/AVC/MPEG-4p10 (2 - 50 Mbps)

Multiplex of A/D/V into MPEG-2 Transport Stream

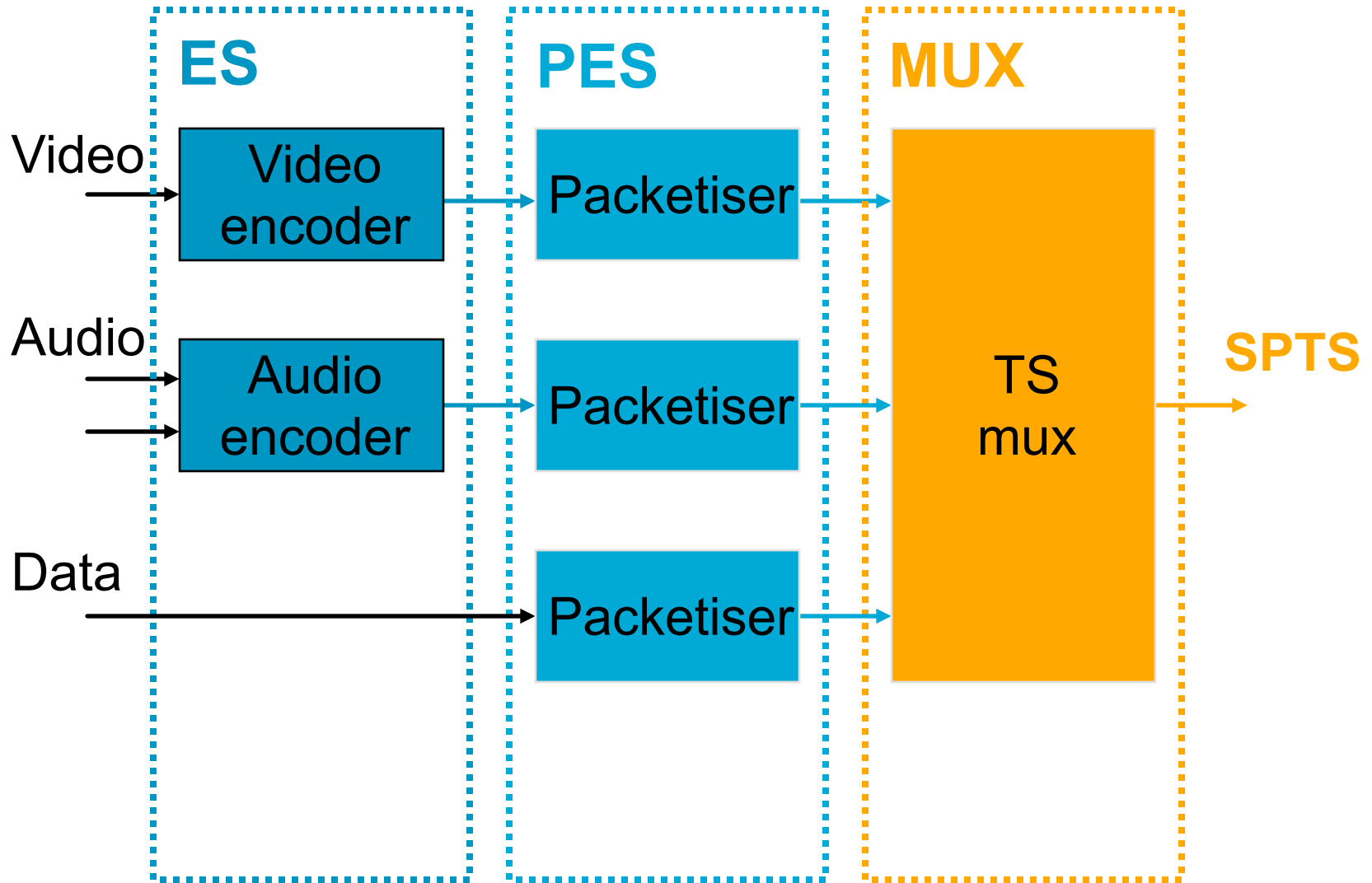

Encapsulation of MPEG-2 TS over IP

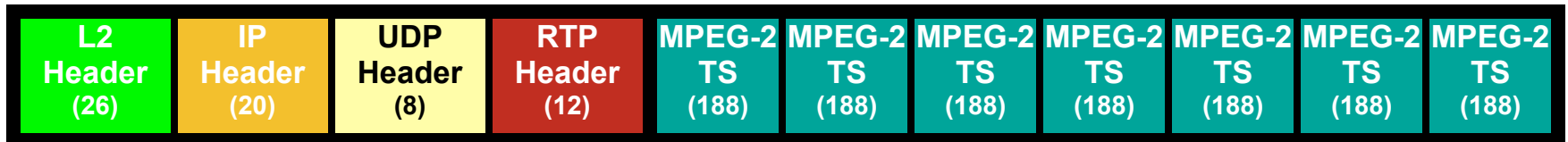
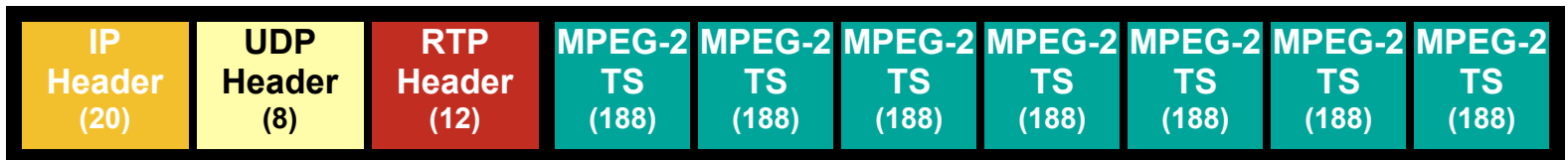
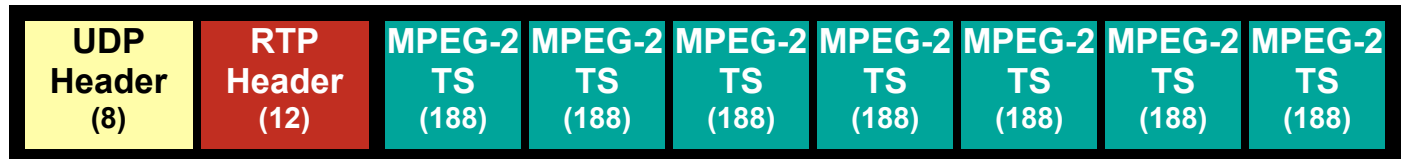
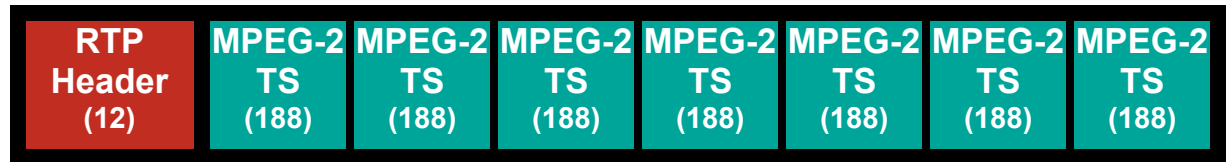

Video requirements



Video SLA Requirements

- Throughput
 - Addressed through capacity planning and QOS (i.e. Diffserv)
- Delay/Jitter
 - Delay variation absorbed by jitter buffer at the end point adapter (STB)
 - Desire to minimise jitter buffer to improve responsiveness (reduce channel change time)
 - Controlled with QOS (i.e. Diffserv) – core contribution to delay variation is insignificant compared to other factors
 - Diffserv is mature technology and premium transport service is known to offer ~ <1msec jitter end-to-end
- Latency - Typically 300 - 500 ms for interactive contribution
 - This includes the encoding - decoding processing
- Loss – controlling loss in the main challenge
- Service Availability
 - The proportion of time for which the specified throughput is available within the bounds of the defined delay and loss - a compound of the other network SLA requirement and network availability

Four Primary Causes for Packet Loss

- **Excess Delay**
 - Packets delayed beyond an acceptable bound are effectively lost
 - Can be prevented with appropriate QoS (i.e., Diffserv)
- **Congestion**
 - Considered a catastrophic case, i.e., a fundamental failure of service
 - Must be prevented with appropriate QoS and admission control
- **PHY-Layer Errors (in the Core)**
 - Can apply in both core and access – although occurrence in core generally insignificant compared to losses due to network failures
- **Network Reconvergence Events**
 - Network level approaches can be used to reduce any loss experienced
 - Application or transport level approaches can be used to recover from loss experienced

Impact of Packet Loss on MPEG Stream

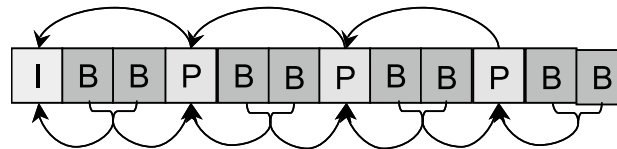

- Compressed Digitized Video is sent as I, B, P Frames
- I-frames: Contain full picture information
 - Transmit I frames approximately every 12-15 frames (GOP interval)
- P-frames: Predicted from past I or P frames
- B-frames: Use past and future I or P frames

I-Frame Loss “Corrupts” P/B Frames for the Entire GOP

Impact of Packet Loss

- Unlike voice, any single unrecovered video packet loss may result in an impairment
- Depending upon specific encoding and compression scheme etc., losses of different packet types are realised as different types of visual impairment
- Video SLA requirements for real-time and streaming video expressed in terms of loss events as *impairments/time*
 - Can also be expressed as mean time between the artefacts (MTBA)
- A commonly used industry benchmark for entertainment-grade IPTV service quality is to deliver MTBA of 2hrs or greater, i.e. no more than one perceivable error during a two-hour movie
- You may decide that the most important metric is in terms of number of support calls received



Slice error



Pixelisation



Ghosting

Architectural solutions



Fast IP routing protocol convergence

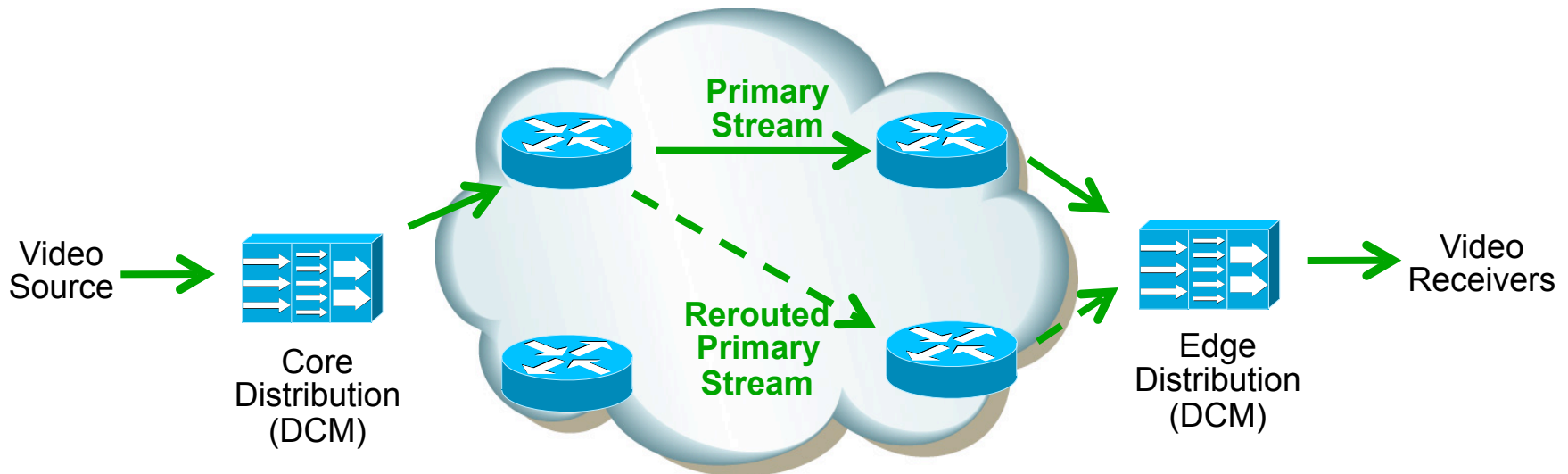

- Implementation and protocol optimisations that can deliver sub second convergence times for unicast (OSPF, ISIS, BGP) and multicast (PIM)
- Network IP routing protocol reconverges on core network failure (link or node); loss of connectivity is experienced before the video stream connectivity is restored
- Fast Convergence
 - ✓ Lowest bandwidth requirements in working and failure case
 - ✓ Lowest solution cost and complexity
 - ! Requires fast converging network to minimize visible impact of loss
 - ✗ Is not hitless – will result in a visible artifact to the end users

Multicast (SSM) Fast Convergence

Convergence Time for All Channels Following a Network Failure

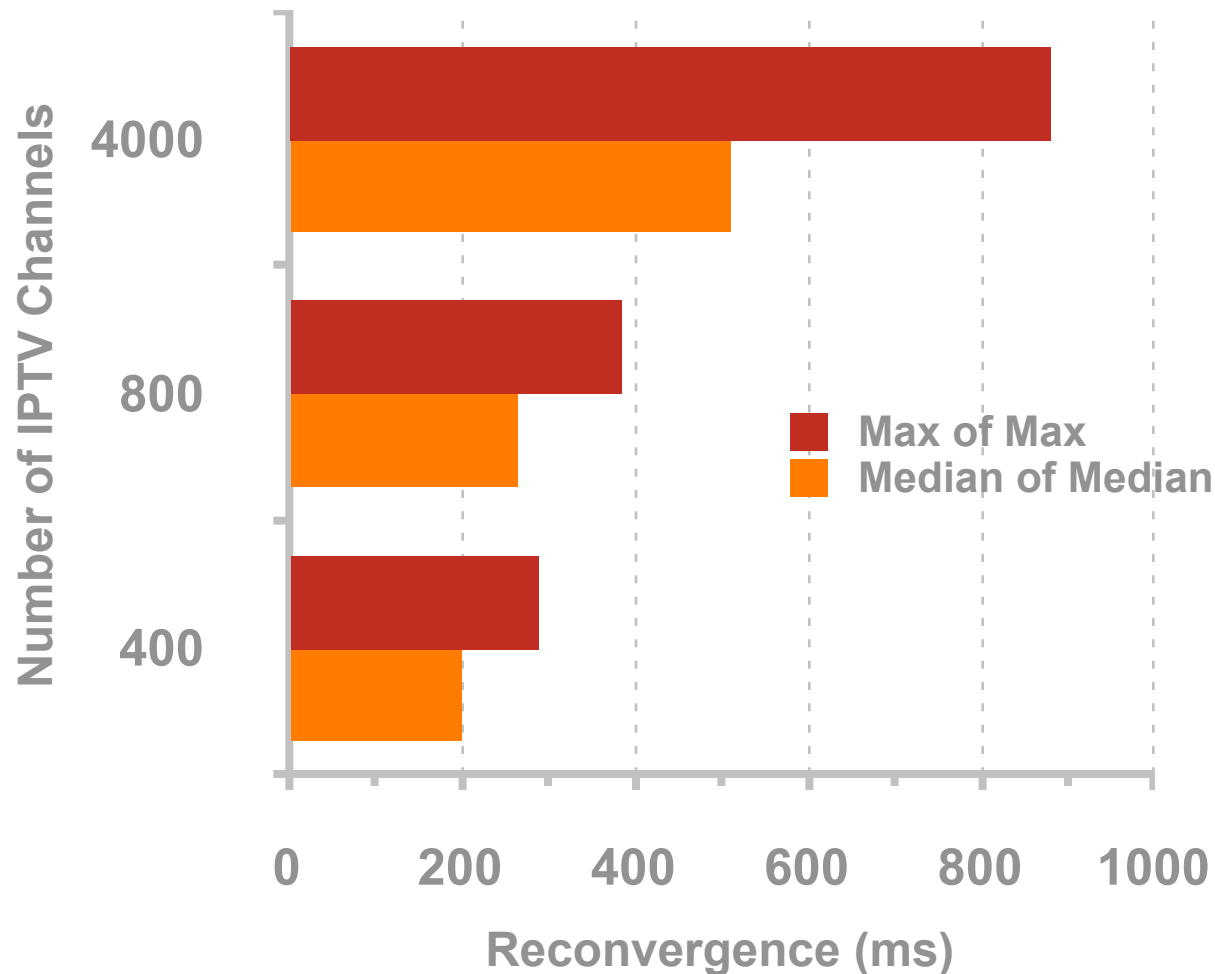

Tested with 2500 IGP prefixes and 250k BGP routes
Impact of multicast convergence on unicast convergence is negligible

Multicast (SSM) Fast Convergence

Convergence Time for All Channels Following a Network Failure

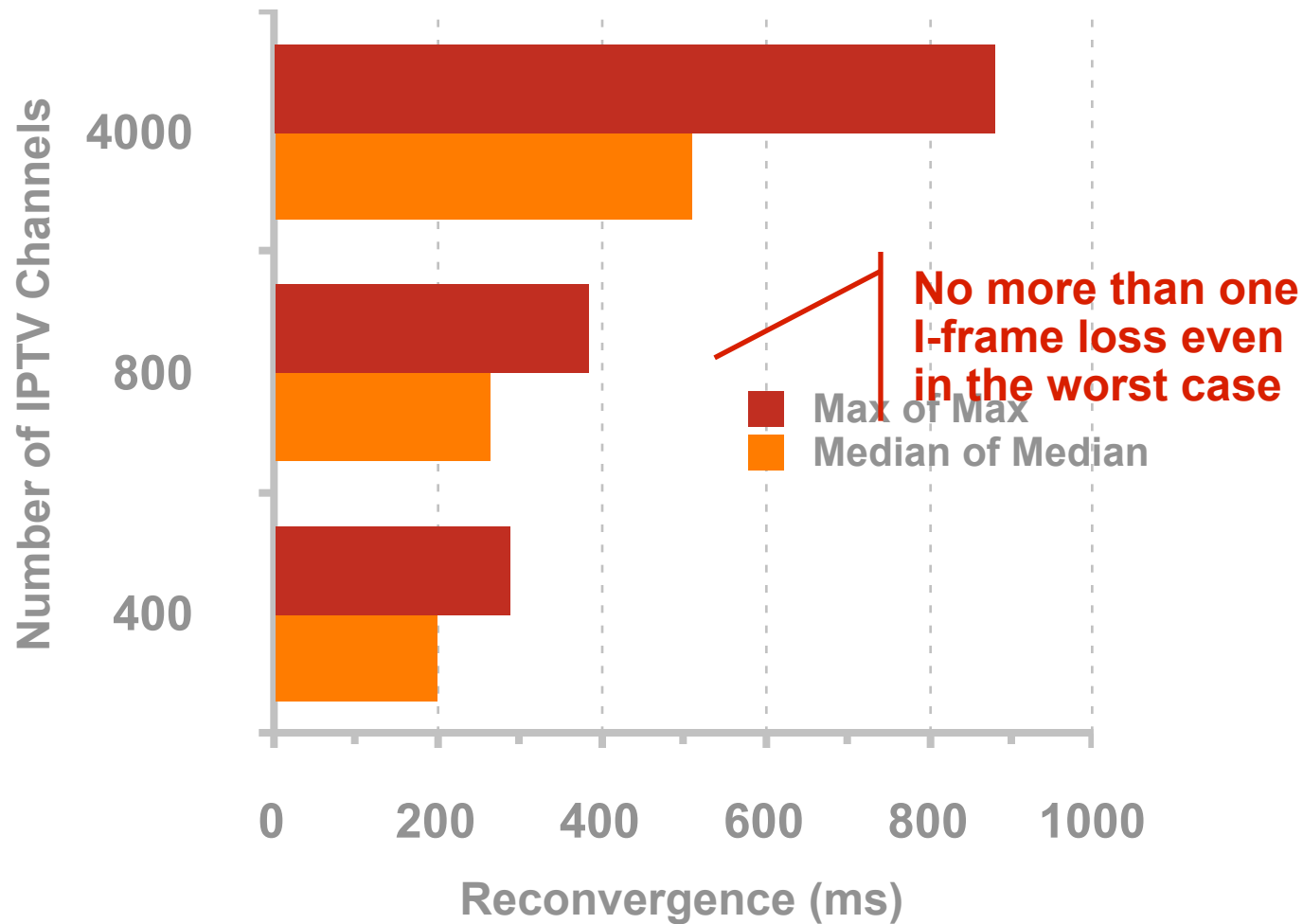

Tested with 2500 IGP prefixes and 250k BGP routes
Impact of multicast convergence on unicast convergence is negligible

Multicast (SSM) Fast Convergence

Convergence Time for All Channels Following a Network Failure

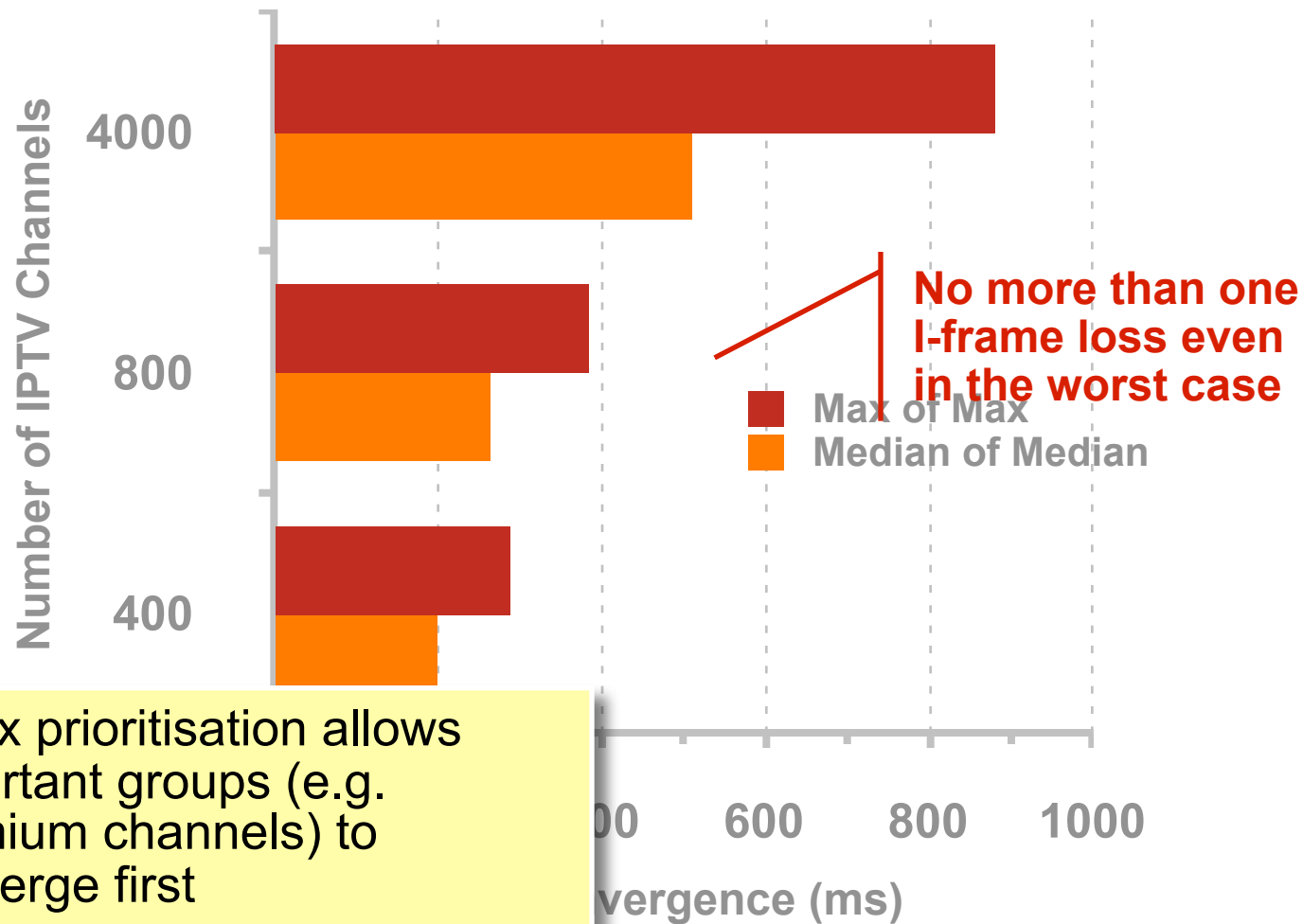

Prefix prioritisation allows important groups (e.g. premium channels) to converge first

Tested with 2500 IGP prefixes and 250k BGP routes
 Impact of multicast convergence on unicast convergence is negligible

Multicast (SSM) Fast Convergence

Convergence Time for All Channels Following a Network Failure

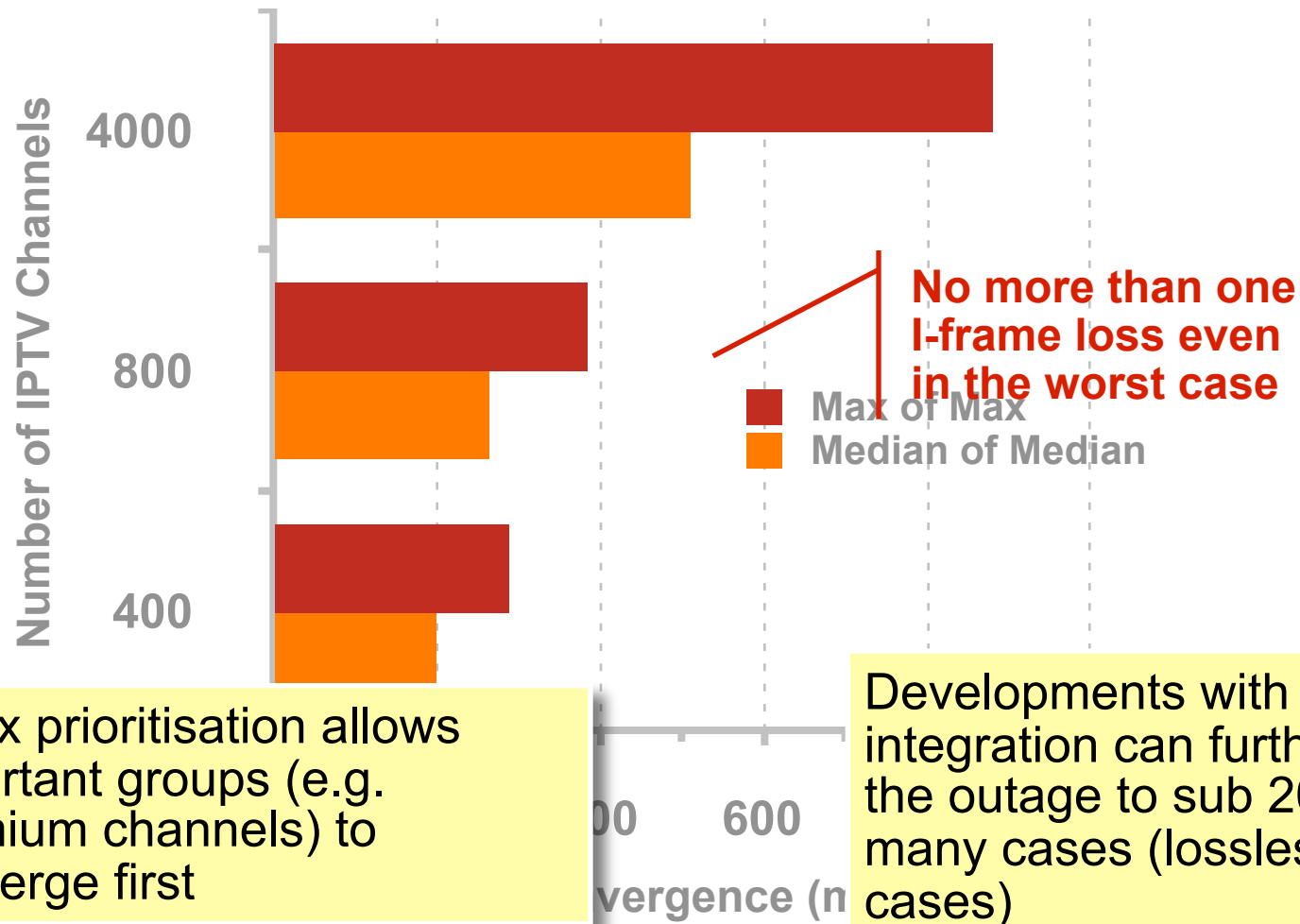

Prefix prioritisation allows important groups (e.g. premium channels) to converge first

Developments with IP optical integration can further reduce the outage to sub 20ms in many cases (lossless in some cases)

Tested with 2500 IGP prefixes and 250k BGP routes
 Impact of multicast convergence on unicast convergence is negligible

IPoDWDM Proactive Protection

- IP / optical integration enables the capability to identify degraded path using optical data (per-FEC BER) and start protection (i.e. by signaling to the IGP) before traffic starts failing, achieving hitless protection in many cases

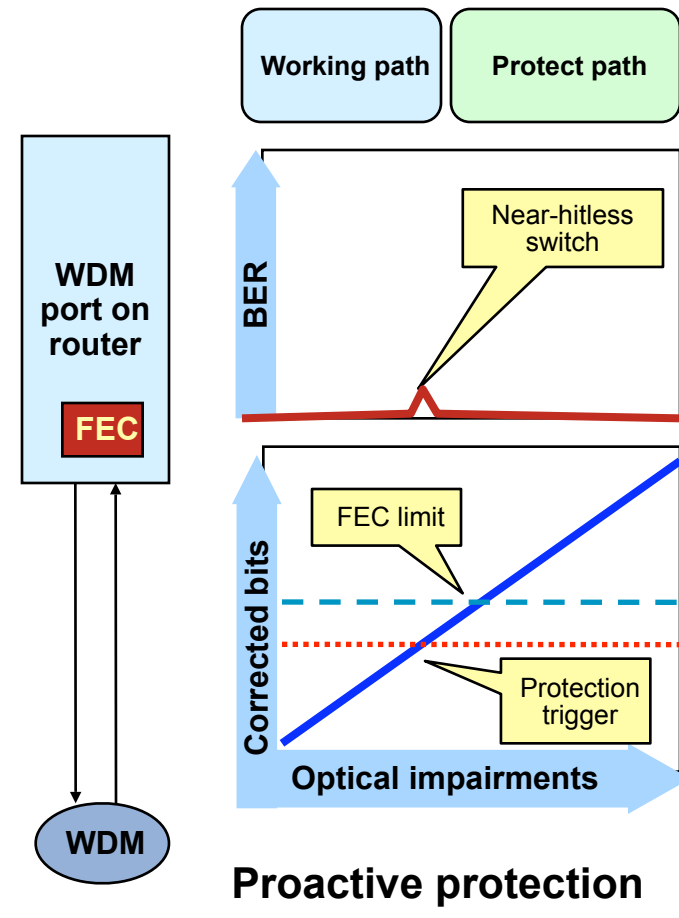
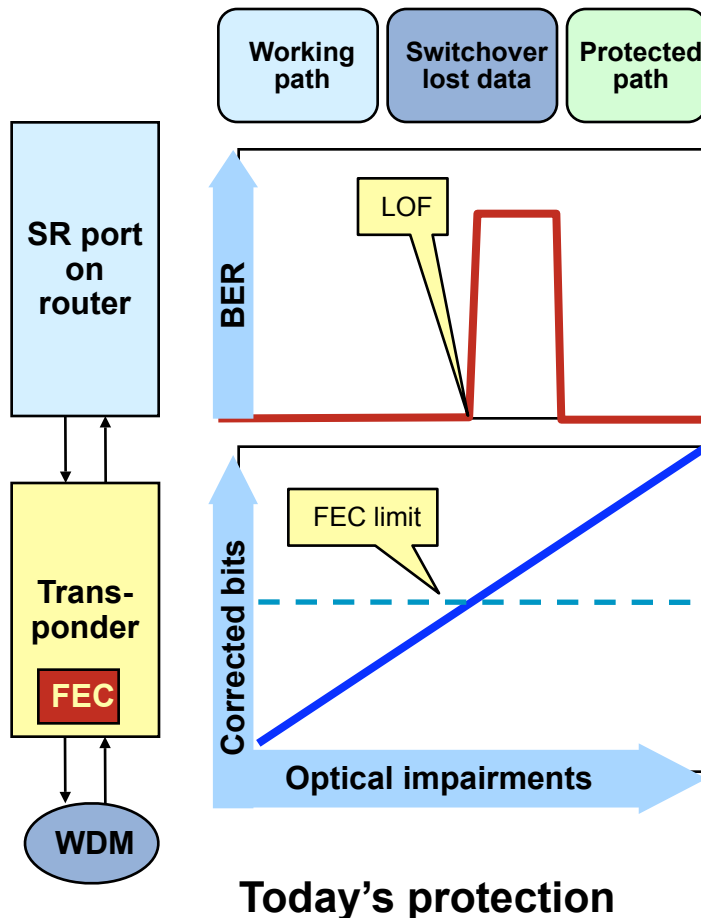

MPLS p2mp TE + Fast Reroute

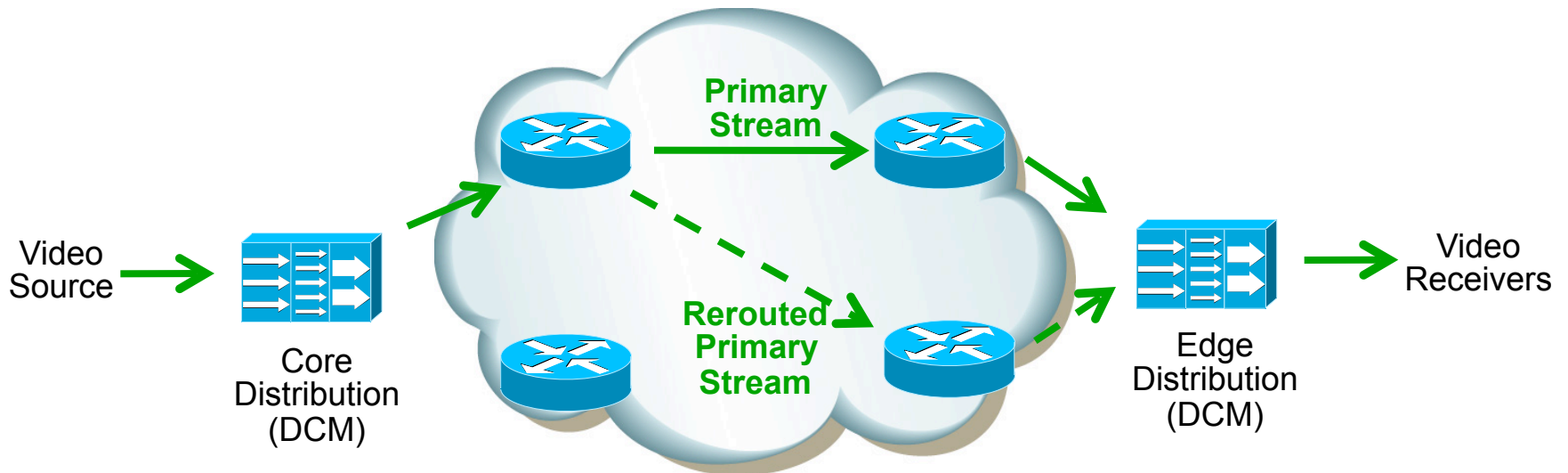

- Enables pre-calculated back up TE tunnels to be used to protect against link failures for rerouting in ~50ms [RFC4090]
- Network reconverges / reroutes on core network failure (link or node); loss of connectivity is experienced before the video stream connectivity is restored
- Fast Reroute
 - ! Requires additional cost and complexity of deploying MPLS TE
 - ! May require that additional bandwidth is provisioned to cover failure cases
 - ✗ Is not hitless – will result in a visible artifact to the end users

MPLS TE FRR Bandwidth Inefficiency

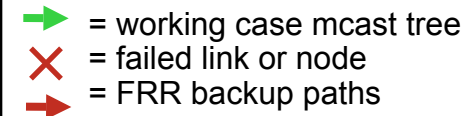

Link Failure

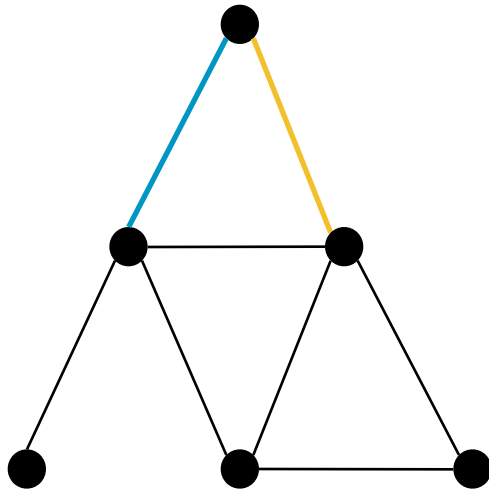

- To protect failure of the orange link, the blue link needs to be provisioned for two times the normal multicast load

Node Failure

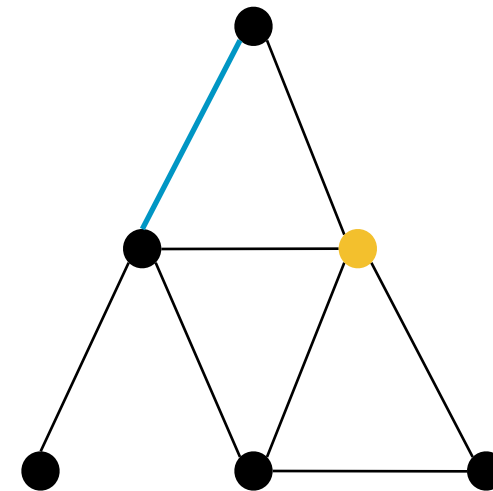

- To protect failure of the orange node, the blue link needs to be provisioned for three times the normal multicast load
- NSF / SSO is a better approach

MPLS TE FRR Bandwidth Inefficiency

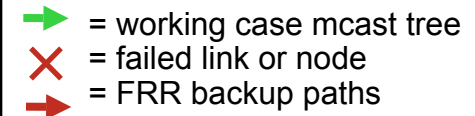

Link Failure

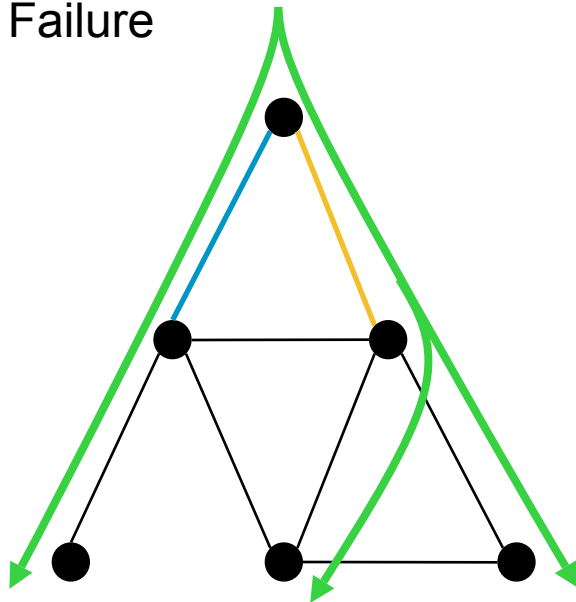

- To protect failure of the orange link, the blue link needs to be provisioned for two times the normal multicast load

Node Failure

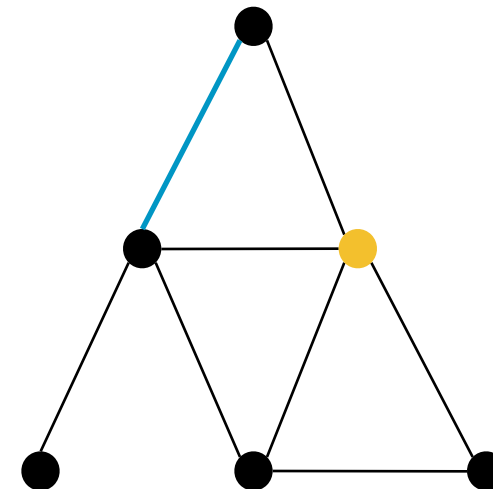

- To protect failure of the orange node, the blue link needs to be provisioned for three times the normal multicast load
- NSF / SSO is a better approach

MPLS TE FRR Bandwidth Inefficiency

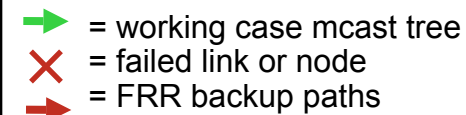

Link Failure

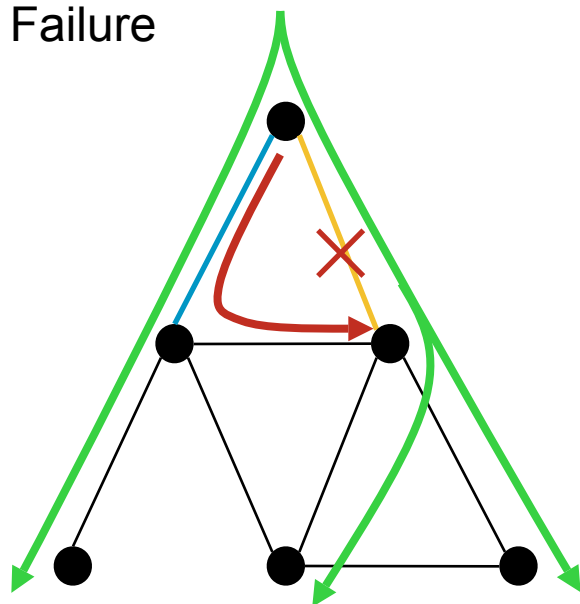

- To protect failure of the orange link, the blue link needs to be provisioned for two times the normal multicast load

Node Failure

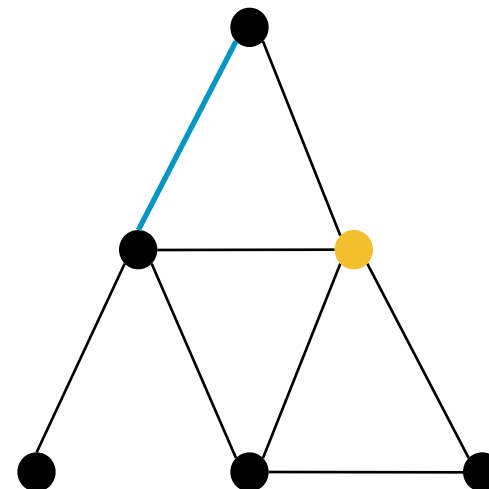

- To protect failure of the orange node, the blue link needs to be provisioned for three times the normal multicast load
- NSF / SSO is a better approach

MPLS TE FRR Bandwidth Inefficiency

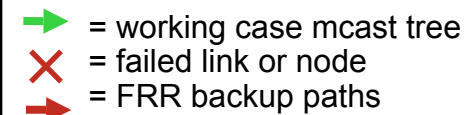

Link Failure

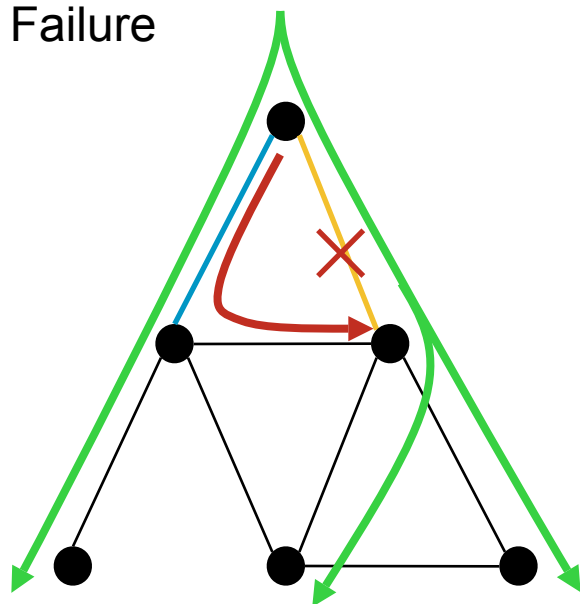

- To protect failure of the orange link, the blue link needs to be provisioned for two times the normal multicast load

Node Failure

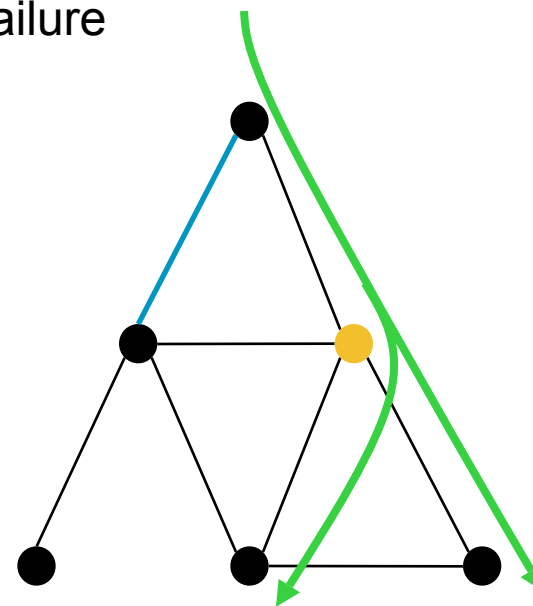

- To protect failure of the orange node, the blue link needs to be provisioned for three times the normal multicast load
- NSF / SSO is a better approach

MPLS TE FRR Bandwidth Inefficiency

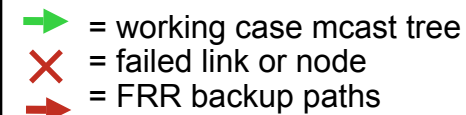

Link Failure

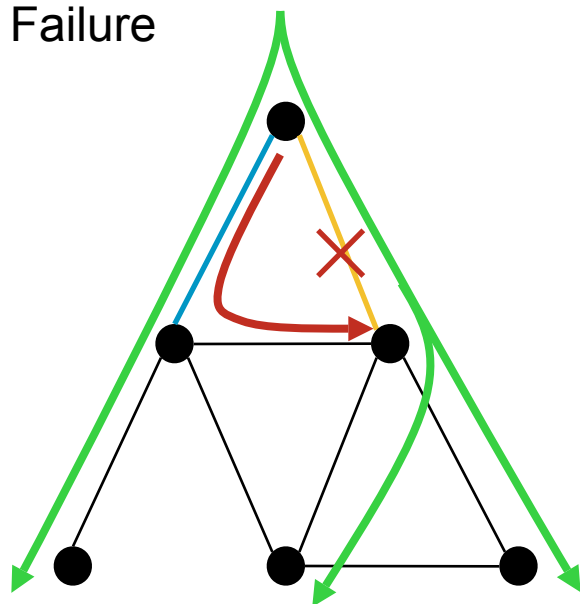

- To protect failure of the orange link, the blue link needs to be provisioned for two times the normal multicast load

Node Failure

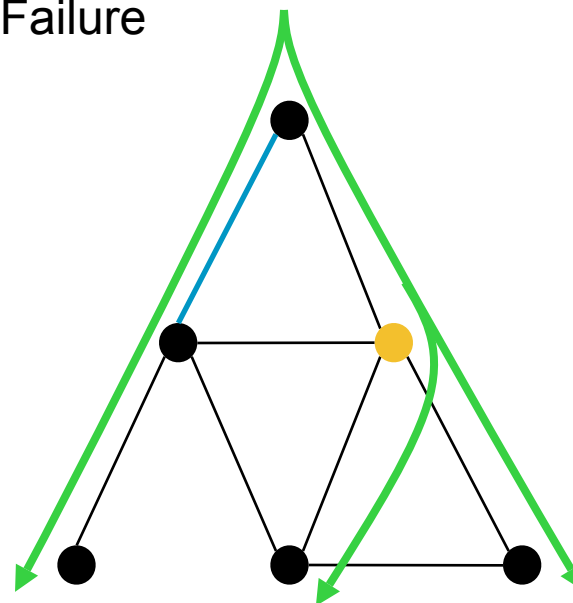

- To protect failure of the orange node, the blue link needs to be provisioned for three times the normal multicast load
- NSF / SSO is a better approach

MPLS TE FRR Bandwidth Inefficiency

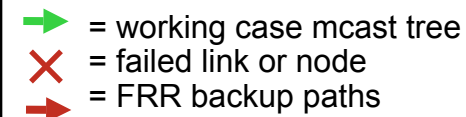

Link Failure

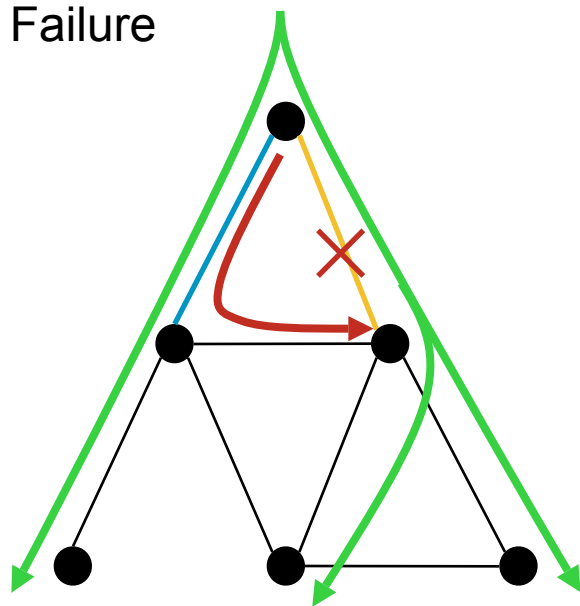

- To protect failure of the orange link, the blue link needs to be provisioned for two times the normal multicast load

Node Failure

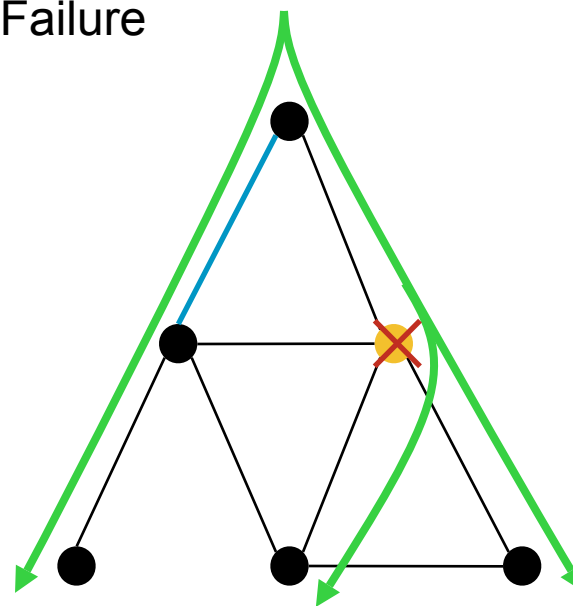

- To protect failure of the orange node, the blue link needs to be provisioned for three times the normal multicast load
- NSF / SSO is a better approach

MPLS TE FRR Bandwidth Inefficiency

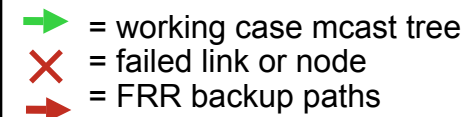

Link Failure

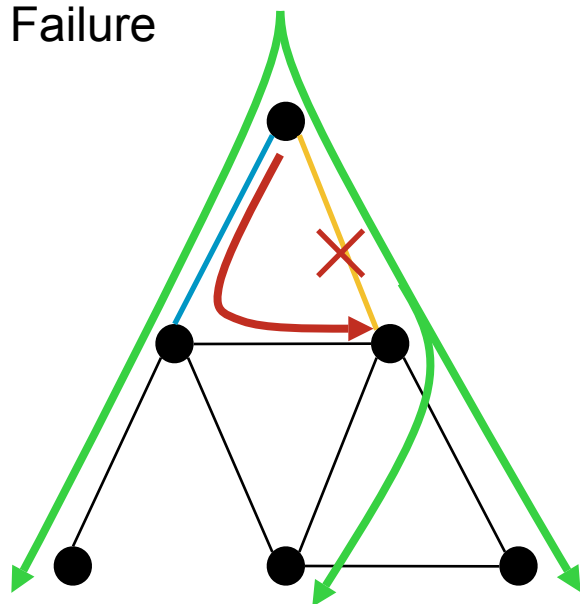

- To protect failure of the orange link, the blue link needs to be provisioned for two times the normal multicast load

Node Failure

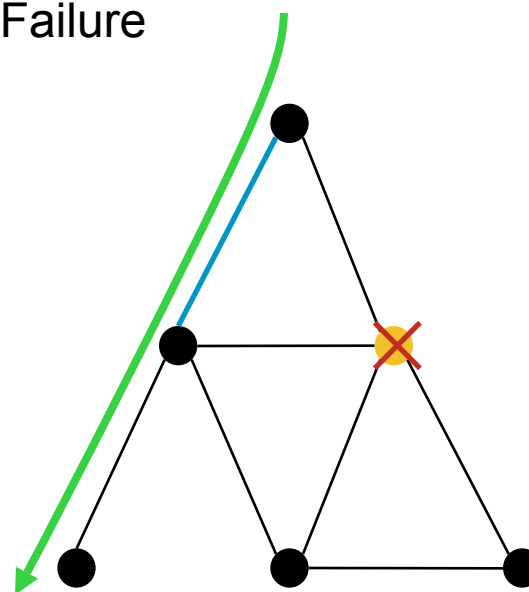

- To protect failure of the orange node, the blue link needs to be provisioned for three times the normal multicast load
- NSF / SSO is a better approach

MPLS TE FRR Bandwidth Inefficiency

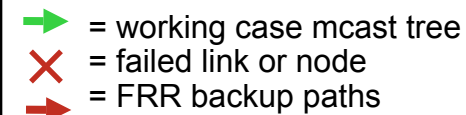

Link Failure

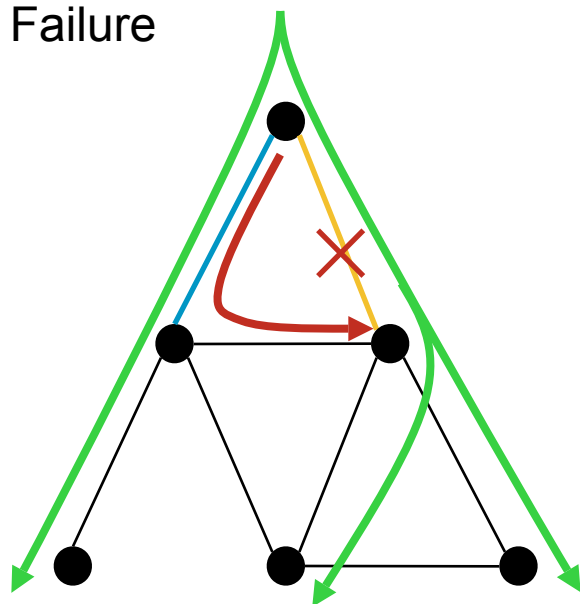

- To protect failure of the orange link, the blue link needs to be provisioned for two times the normal multicast load

Node Failure

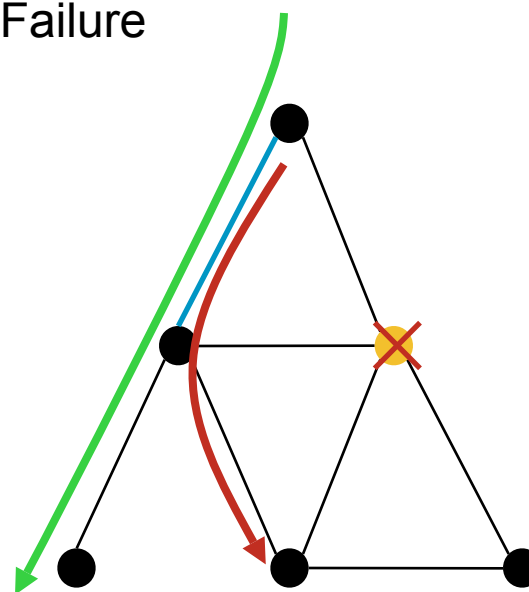

- To protect failure of the orange node, the blue link needs to be provisioned for three times the normal multicast load
- NSF / SSO is a better approach

MPLS TE FRR Bandwidth Inefficiency

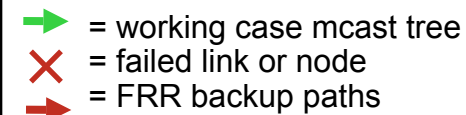

Link Failure

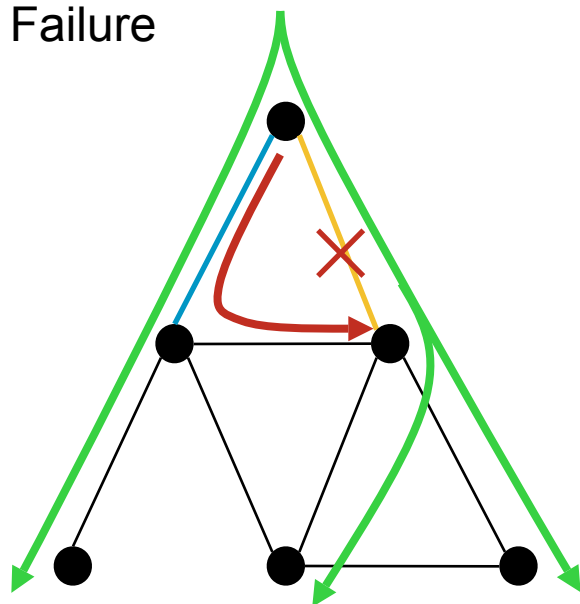

- To protect failure of the orange link, the blue link needs to be provisioned for two times the normal multicast load

Node Failure

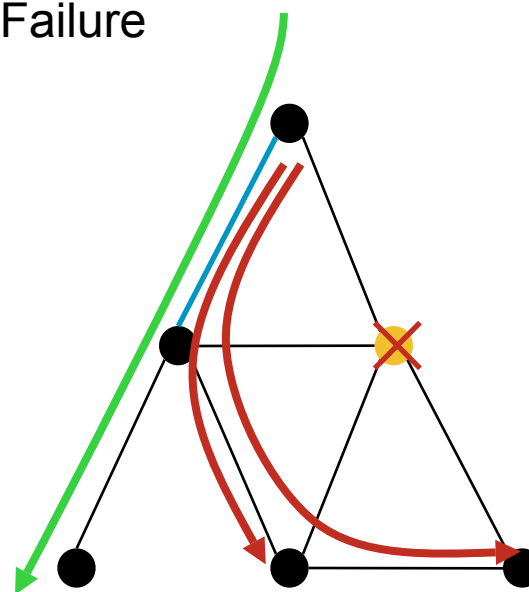

- To protect failure of the orange node, the blue link needs to be provisioned for three times the normal multicast load
- NSF / SSO is a better approach

Application Layer Forward Error Correction (AL-FEC)

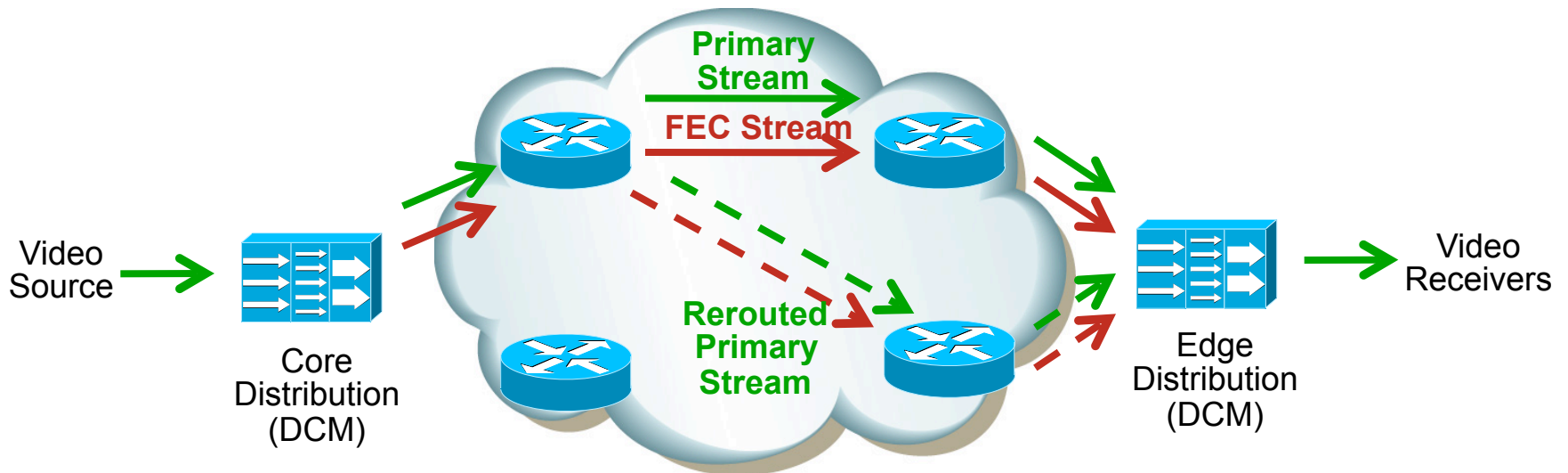

- AL-FEC adds redundancy to the transmitted data to allow the receiver to detect and correct errors (within some bound) without the need to resend any data
- Forward Error Correction
 - ✓ Supports hitless recovery from loss due to core network failures if loss can be constrained
 - ✓ No requirement for network path diversity – works for all topologies
 - ! Requires fast converging network to minimize FEC overhead
 - ✗ Higher overall bandwidth consumed in failure case compared to spatial redundancy
 - ✗ Incurs delay – longer outages require larger overhead or larger block sizes (more delay)

FEC: Overhead vs. Outage

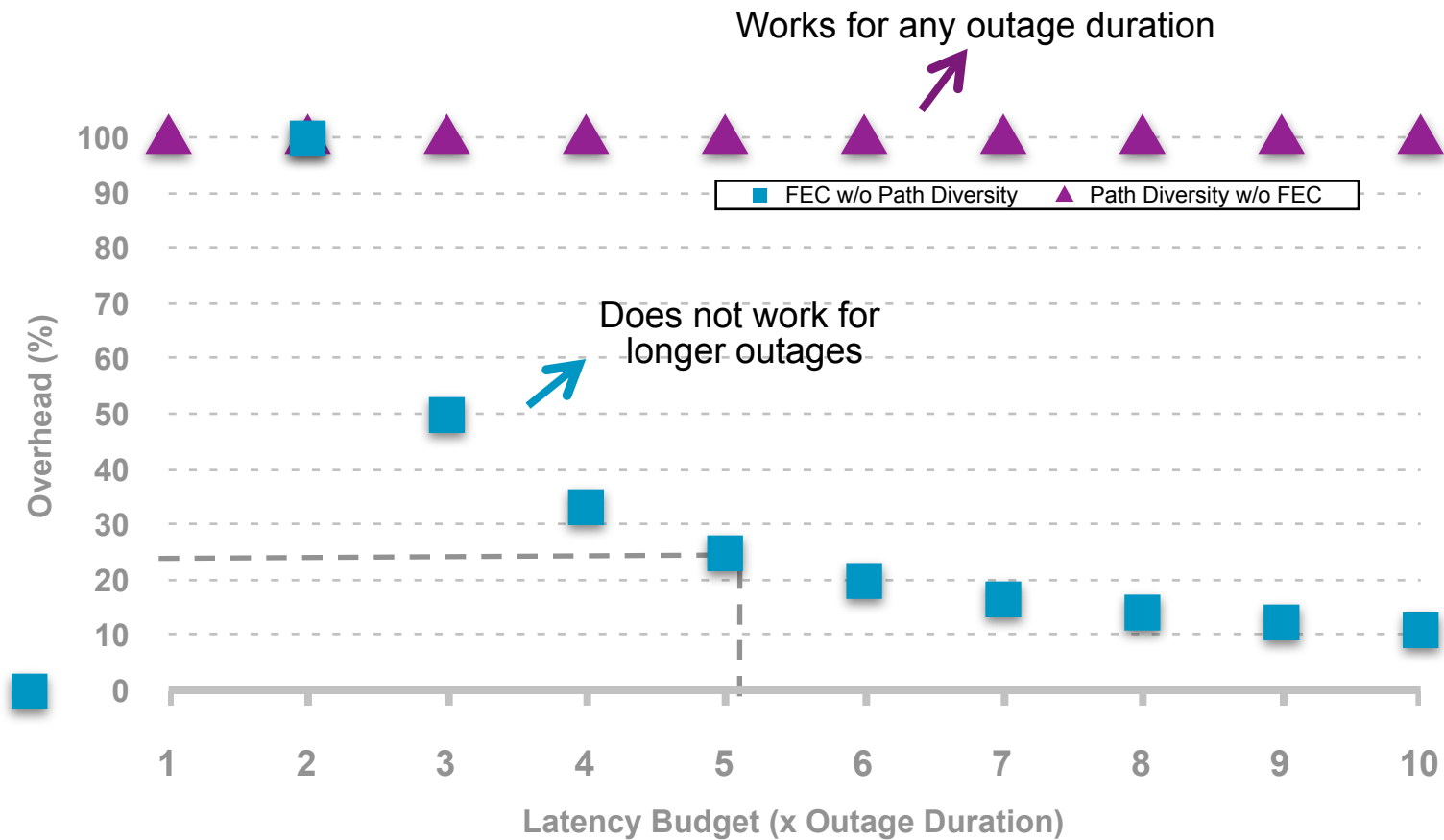

FEC: Overhead vs. Outage

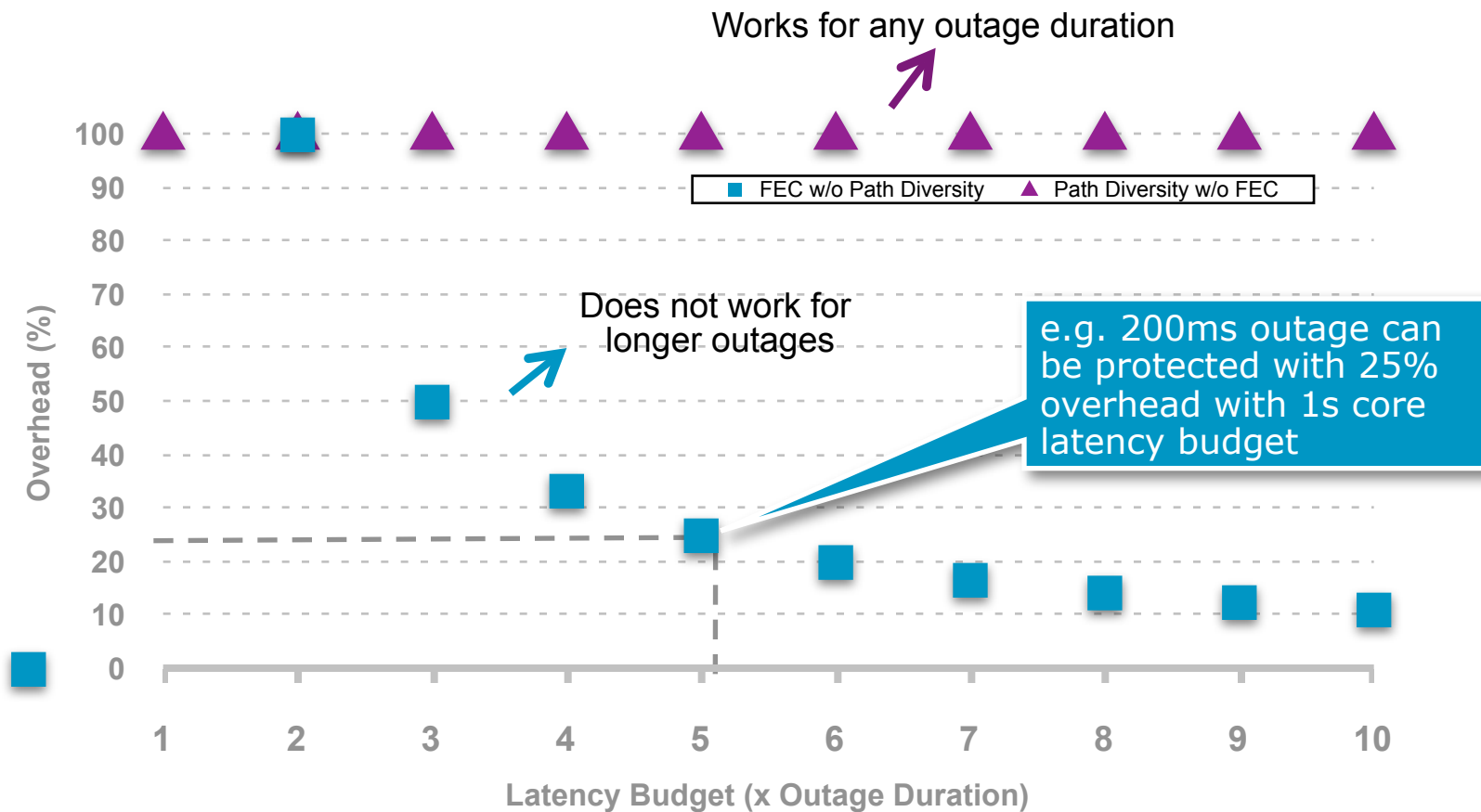

Spatial (Path) Diversity (a.k.a “live / live”)

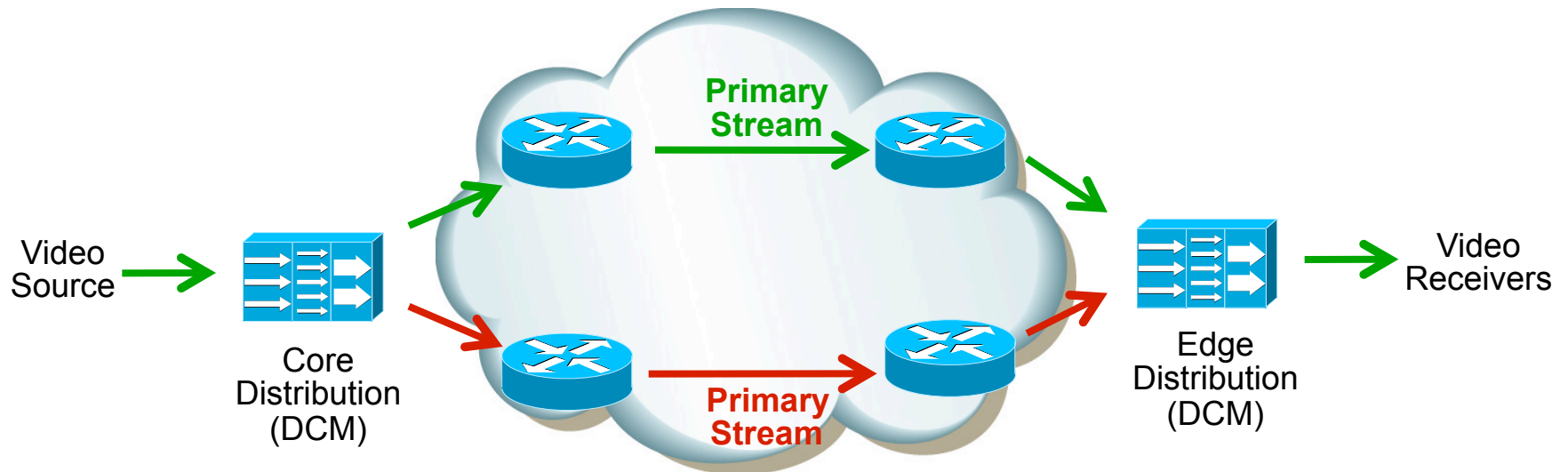

- Two streams are sent over diverse network paths between the sender and receiver
- Spatial diversity
 - ✓ Supports hitless recovery from loss due to core network failures with packet by packet stream merge functions (e.g. DCM)
 - ✓ Lower overall bandwidth consumed in failure case compared to FEC
 - ✓ Introduces no delay if the paths have equal propagation delays
 - ! May require network-level techniques to ensure spatial diversity: MoFRR, MPLS TE, MTR – required techniques depend upon topology

Multicast only FRR (MoFRR)

- It is make-before-break solution
- Multicast routing doesn't have to wait for unicast routing to converge
- An alternative to source redundancy, but:
 - Don't have to provision sources
 - Don't have to sync data streams
 - No duplicate data to multicast receivers
- No repair tunnels
- No new setup protocols
- No forwarding/hardware changes



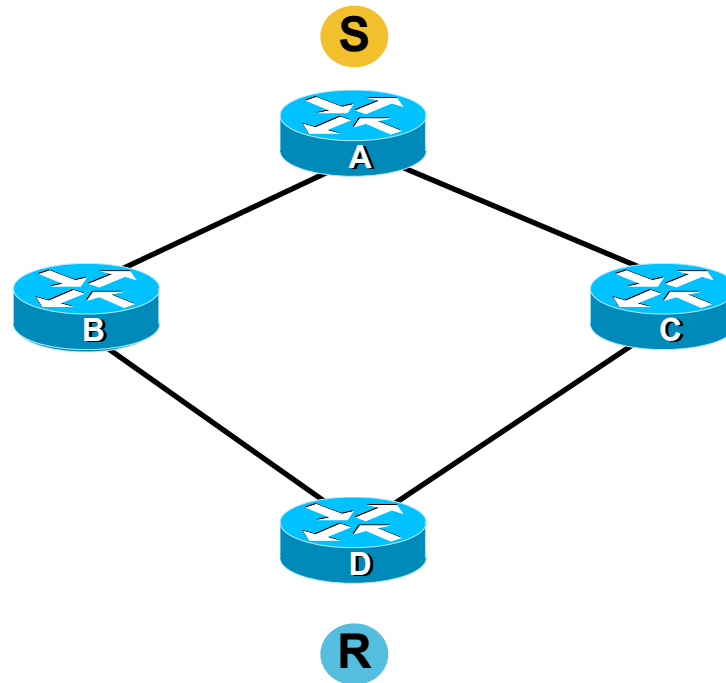

Concept Example

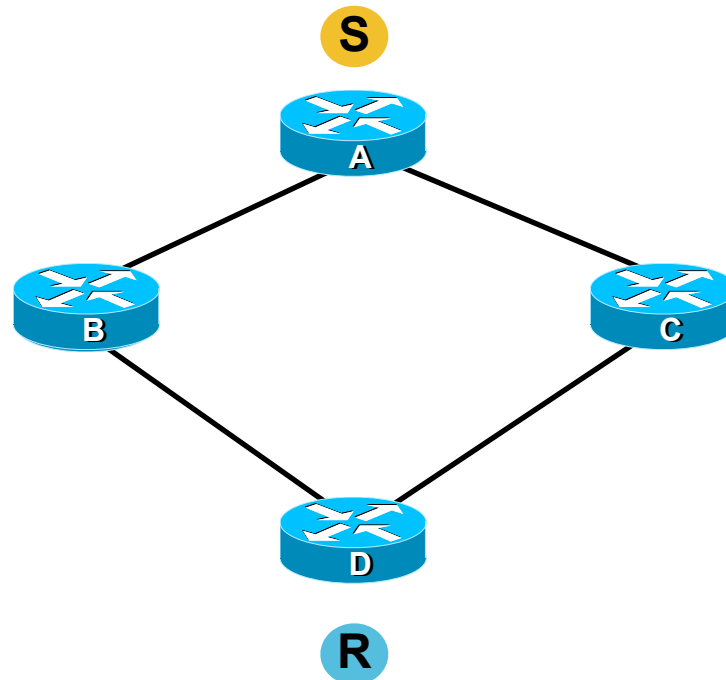

- ➔ Data Path
- ➔ rpf Path (RPF Join)
- ⋯➔ Alt Join (Sent on Non-rpf)
- Interface in oif-list
- ⬮ Link Down or RPF-Failed Packet Drop

Concept Example





-  Data Path
-  rpf Path (RPF Join)
-  Alt Join (Sent on Non-rpf)
-  Interface in oif-list
-  Link Down or RPF-Failed Packet Drop

1. D has ECMP path {BA, CA} to S
2. D sends join on RPF path through C
3. D can send alternate-join on BA path
4. A has 2 oifs leading to a single receiver
5. When RPF path is up, duplicates come to D
6. But D RPF fails on packets from B

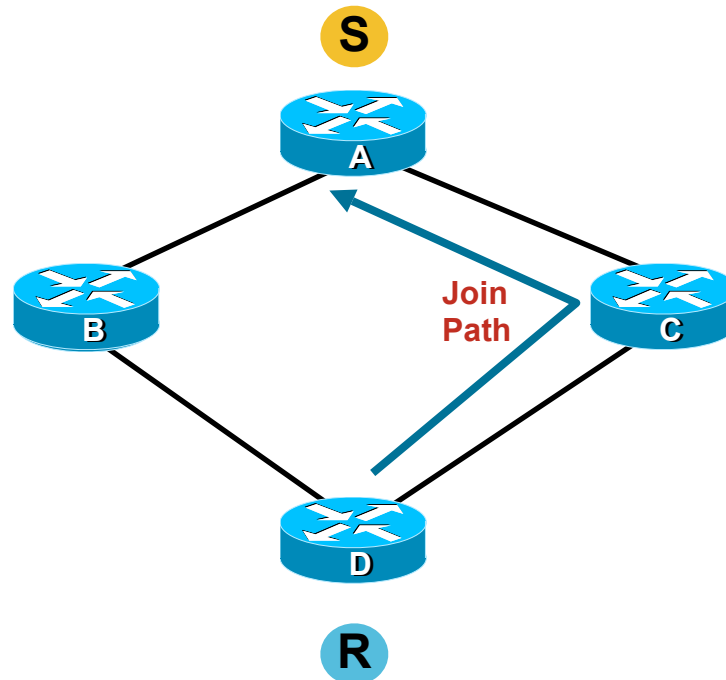
Concept Example



-  Data Path
-  rpf Path (RPF Join)
-  Alt Join (Sent on Non-rpf)
-  Interface in oif-list
-  Link Down or RPF-Failed Packet Drop

1. D has ECMP path {BA, CA} to S
2. D sends join on RPF path through C
3. D can send alternate-join on BA path
4. A has 2 oifs leading to a single receiver
5. When RPF path is up, duplicates come to D
6. But D RPF fails on packets from B

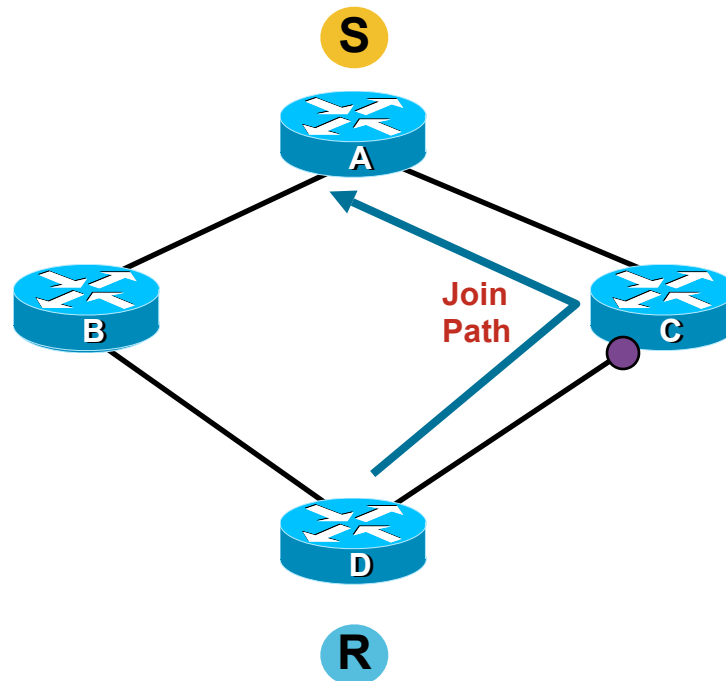

Concept Example

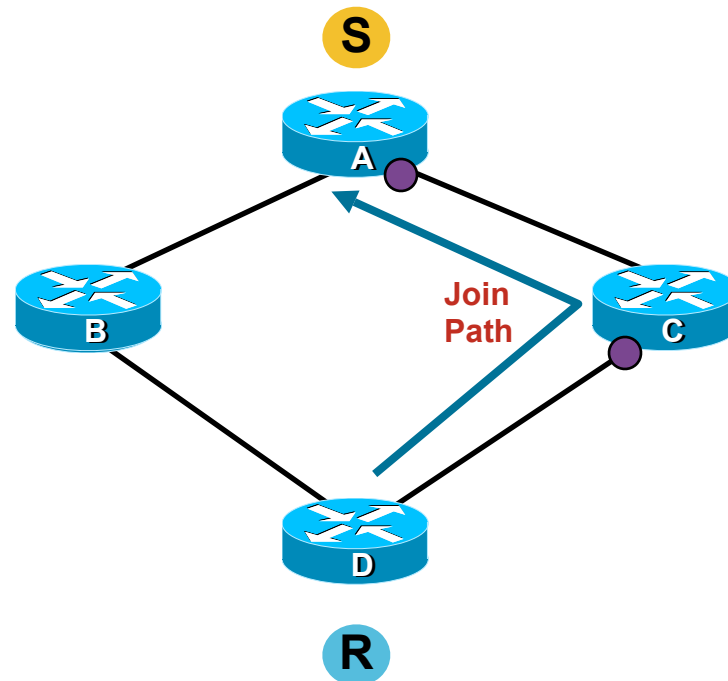

1. D has ECMP path {BA, CA} to S
2. D sends join on RPF path through C
3. D can send alternate-join on BA path
4. A has 2 oifs leading to a single receiver
5. When RPF path is up, duplicates come to D
6. But D RPF fails on packets from B

Concept Example





-  Data Path
-  rpf Path (RPF Join)
-  Alt Join (Sent on Non-rpf)
-  Interface in oif-list
-  Link Down or RPF-Failed Packet Drop

1. D has ECMP path {BA, CA} to S
2. D sends join on RPF path through C
3. D can send alternate-join on BA path
4. A has 2 oifs leading to a single receiver
5. When RPF path is up, duplicates come to D
6. But D RPF fails on packets from B

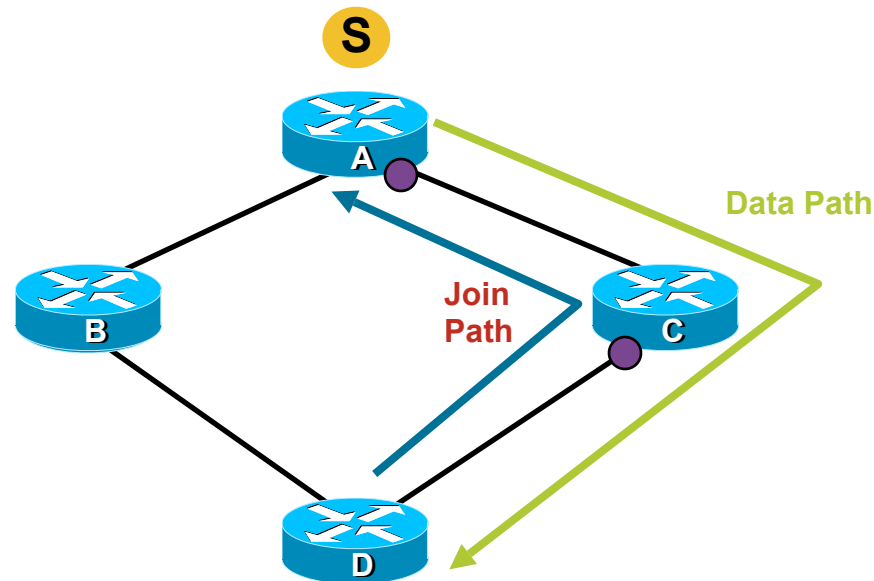
Concept Example







-  Data Path
-  rpf Path (RPF Join)
-  Alt Join (Sent on Non-rpf)
-  Interface in oif-list
-  Link Down or RPF-Failed Packet Drop

R

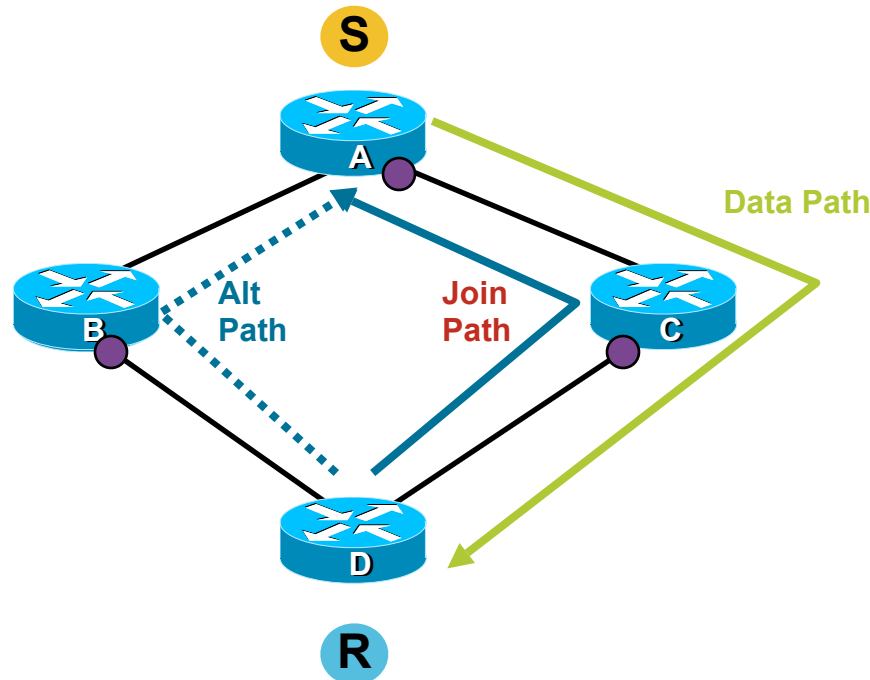
1. D has ECMP path {BA, CA} to S
2. D sends join on RPF path through C
3. D can send alternate-join on BA path
4. A has 2 oifs leading to a single receiver
5. When RPF path is up, duplicates come to D
6. But D RPF fails on packets from B

Concept Example





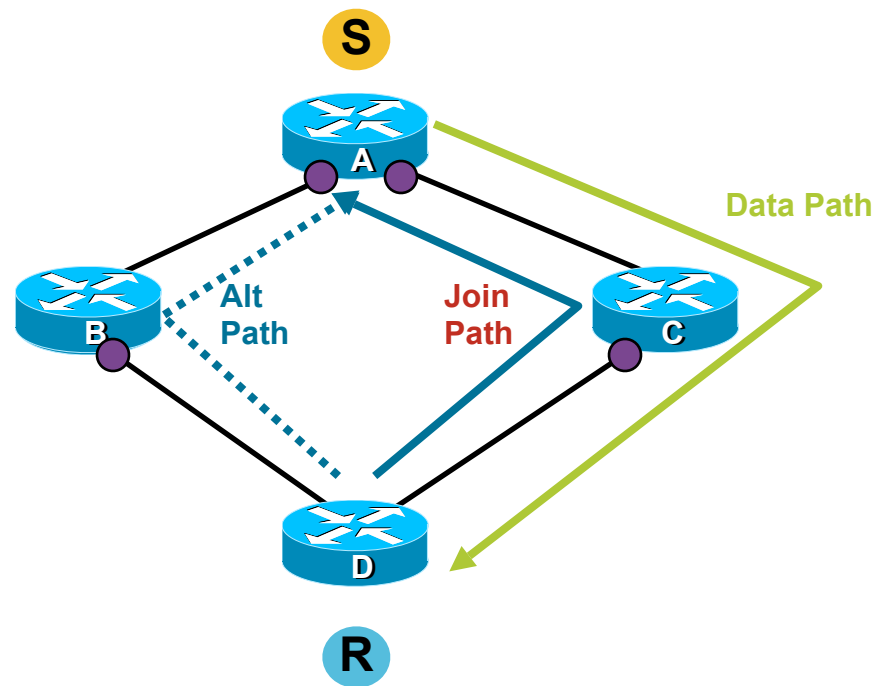

-  Data Path
-  rpf Path (RPF Join)
-  Alt Join (Sent on Non-rpf)
-  Interface in oif-list
-  Link Down or RPF-Failed Packet Drop

- R**
1. D has ECMP path {BA, CA} to S
 2. D sends join on RPF path through C
 3. D can send alternate-join on BA path
 4. A has 2 oifs leading to a single receiver
 5. When RPF path is up, duplicates come to D
 6. But D RPF fails on packets from B

Concept Example





-  Data Path
-  rpf Path (RPF Join)
-  Alt Join (Sent on Non-rpf)
-  Interface in oif-list
-  Link Down or RPF-Failed Packet Drop

1. D has ECMP path {BA, CA} to S
2. D sends join on RPF path through C
3. D can send alternate-join on BA path
4. A has 2 oifs leading to a single receiver
5. When RPF path is up, duplicates come to D
6. But D RPF fails on packets from B

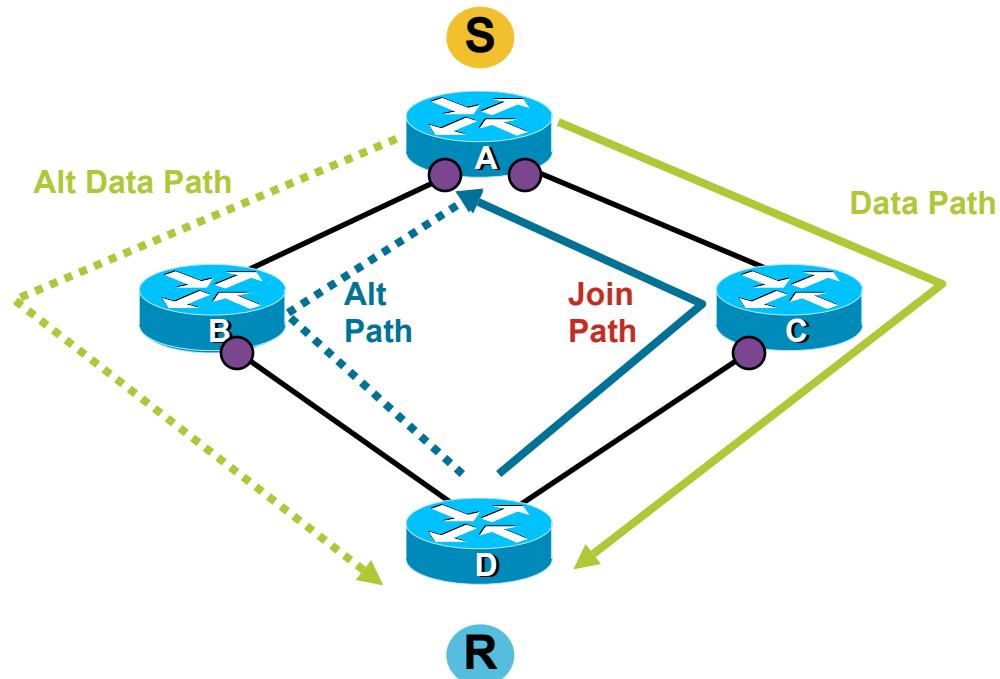
Concept Example





-  Data Path
-  rpf Path (RPF Join)
-  Alt Join (Sent on Non-rpf)
-  Interface in oif-list
-  Link Down or RPF-Failed Packet Drop

1. D has ECMP path {BA, CA} to S
2. D sends join on RPF path through C
3. D can send alternate-join on BA path
4. A has 2 oifs leading to a single receiver
5. When RPF path is up, duplicates come to D
6. But D RPF fails on packets from B

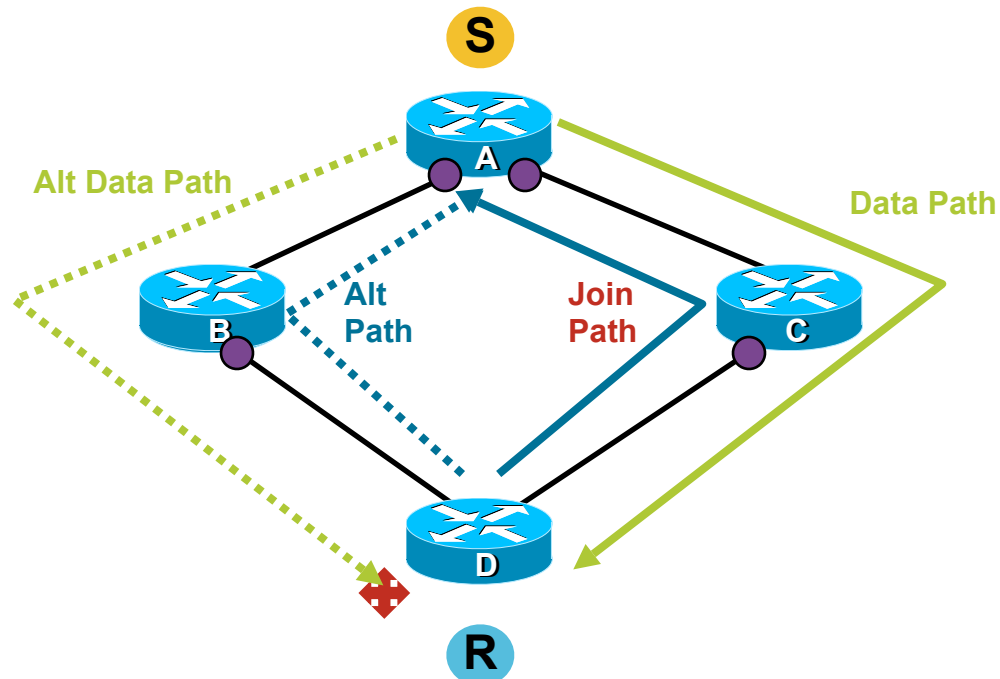
Concept Example





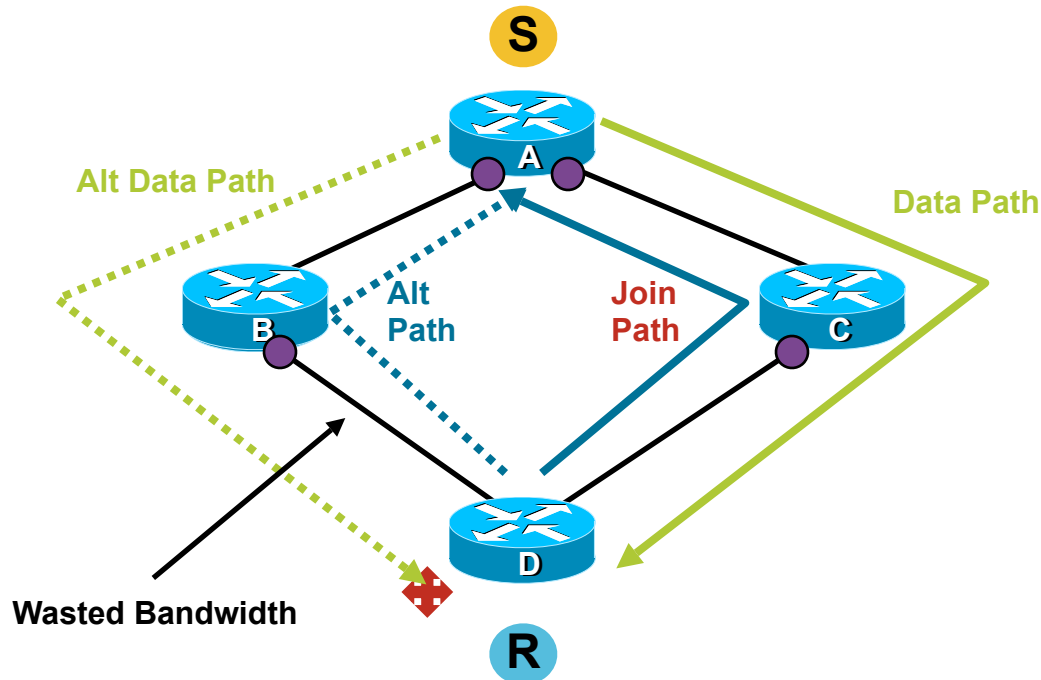

-  Data Path
-  rpf Path (RPF Join)
-  Alt Join (Sent on Non-rpf)
-  Interface in oif-list
-  Link Down or RPF-Failed Packet Drop

1. D has ECMP path {BA, CA} to S
2. D sends join on RPF path through C
3. D can send alternate-join on BA path
4. A has 2 oifs leading to a single receiver
5. When RPF path is up, duplicates come to D
6. But D RPF fails on packets from B

Concept Example





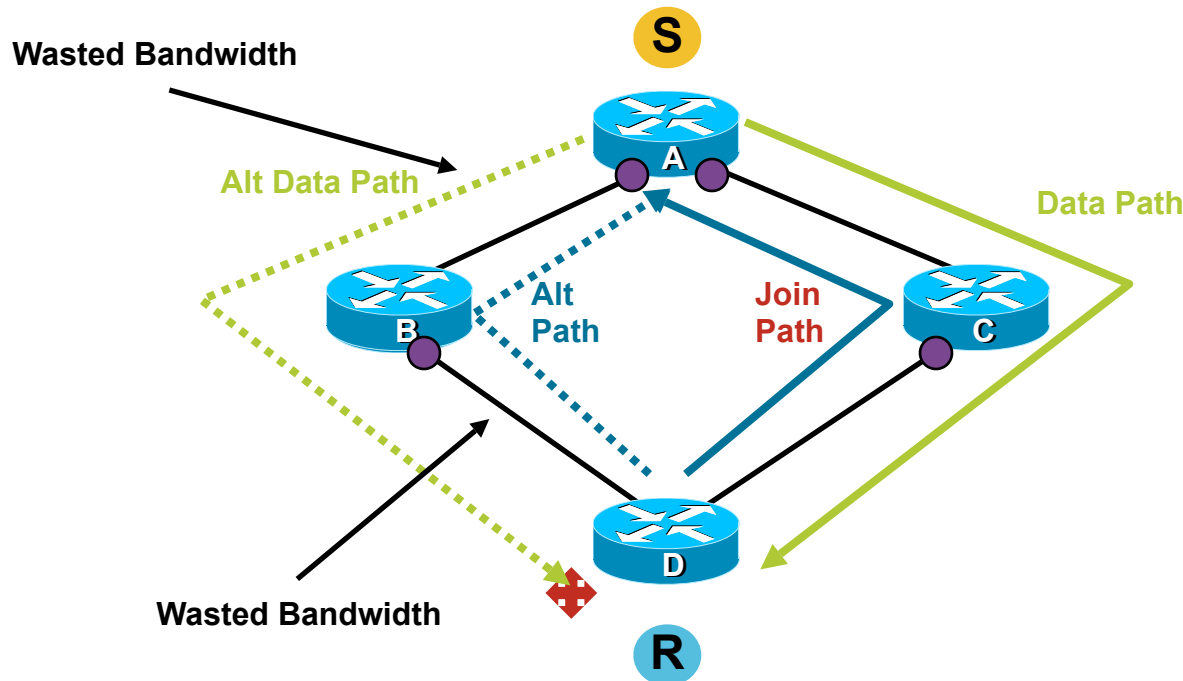

-  Data Path
-  rpf Path (RPF Join)
-  Alt Join (Sent on Non-rpf)
-  Interface in oif-list
-  Link Down or RPF-Failed Packet Drop

1. D has ECMP path {BA, CA} to S
2. D sends join on RPF path through C
3. D can send alternate-join on BA path
4. A has 2 oifs leading to a single receiver
5. When RPF path is up, duplicates come to D
6. But D RPF fails on packets from B

Concept Example



-  Data Path
-  rpf Path (RPF Join)
-  Alt Join (Sent on Non-rpf)
-  Interface in oif-list
-  Link Down or RPF-Failed Packet Drop

1. D has ECMP path {BA, CA} to S
2. D sends join on RPF path through C
3. D can send alternate-join on BA path
4. A has 2 oifs leading to a single receiver
5. When RPF path is up, duplicates come to D
6. But D RPF fails on packets from B

Concept Example

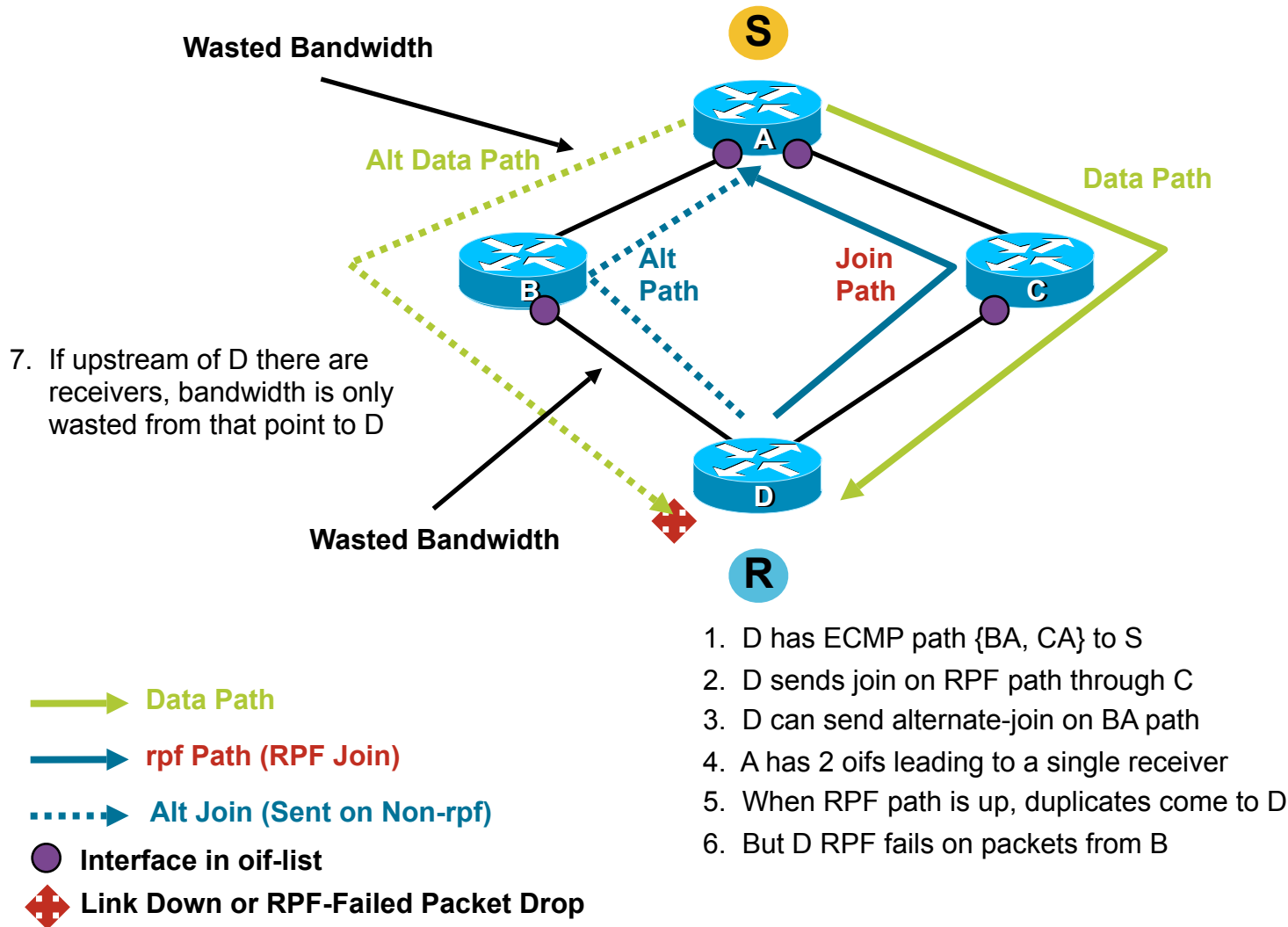



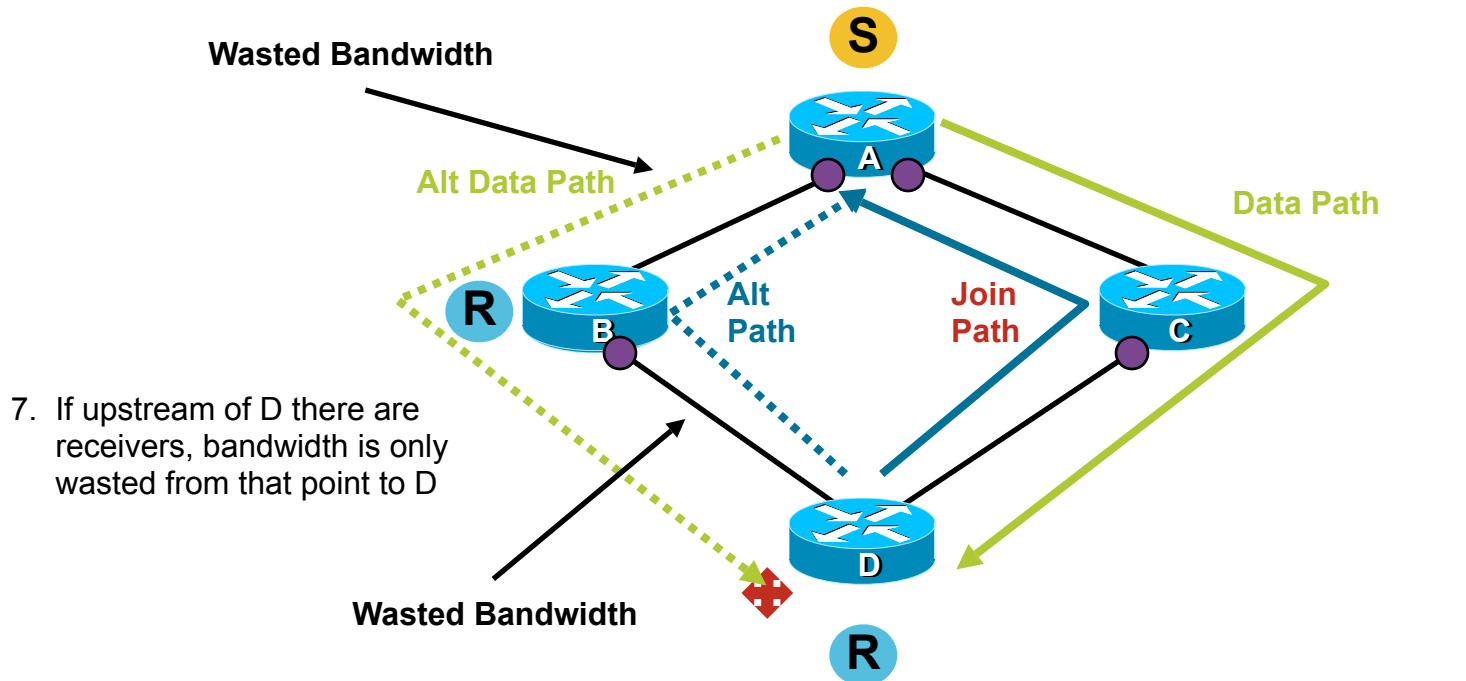

1. D has ECMP path {BA, CA} to S
2. D sends join on RPF path through C
3. D can send alternate-join on BA path
4. A has 2 oifs leading to a single receiver
5. When RPF path is up, duplicates come to D
6. But D RPF fails on packets from B

Concept Example



7. If upstream of D there are receivers, bandwidth is only wasted from that point to D

1. D has ECMP path {BA, CA} to S
2. D sends join on RPF path through C
3. D can send alternate-join on BA path
4. A has 2 oifs leading to a single receiver
5. When RPF path is up, duplicates come to D
6. But D RPF fails on packets from B



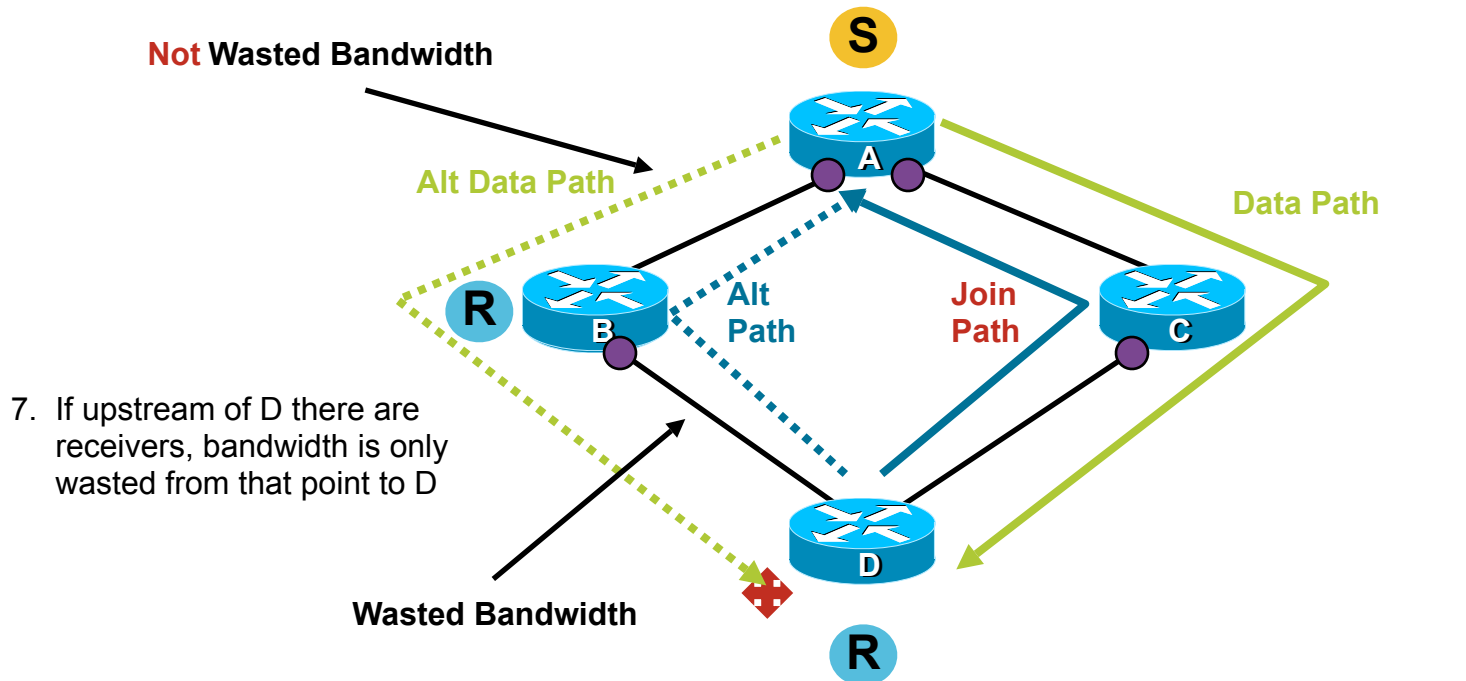

-  Data Path
-  rpf Path (RPF Join)
-  Alt Join (Sent on Non-rpf)
-  Interface in oif-list
-  Link Down or RPF-Failed Packet Drop

Concept Example



7. If upstream of D there are receivers, bandwidth is only wasted from that point to D

1. D has ECMP path {BA, CA} to S
2. D sends join on RPF path through C
3. D can send alternate-join on BA path
4. A has 2 oifs leading to a single receiver
5. When RPF path is up, duplicates come to D
6. But D RPF fails on packets from B

-  **Data Path**
-  **rpf Path (RPF Join)**
-  **Alt Join (Sent on Non-rpf)**
-  **Interface in oif-list**
-  **Link Down or RPF-Failed Packet Drop**

Concept Example

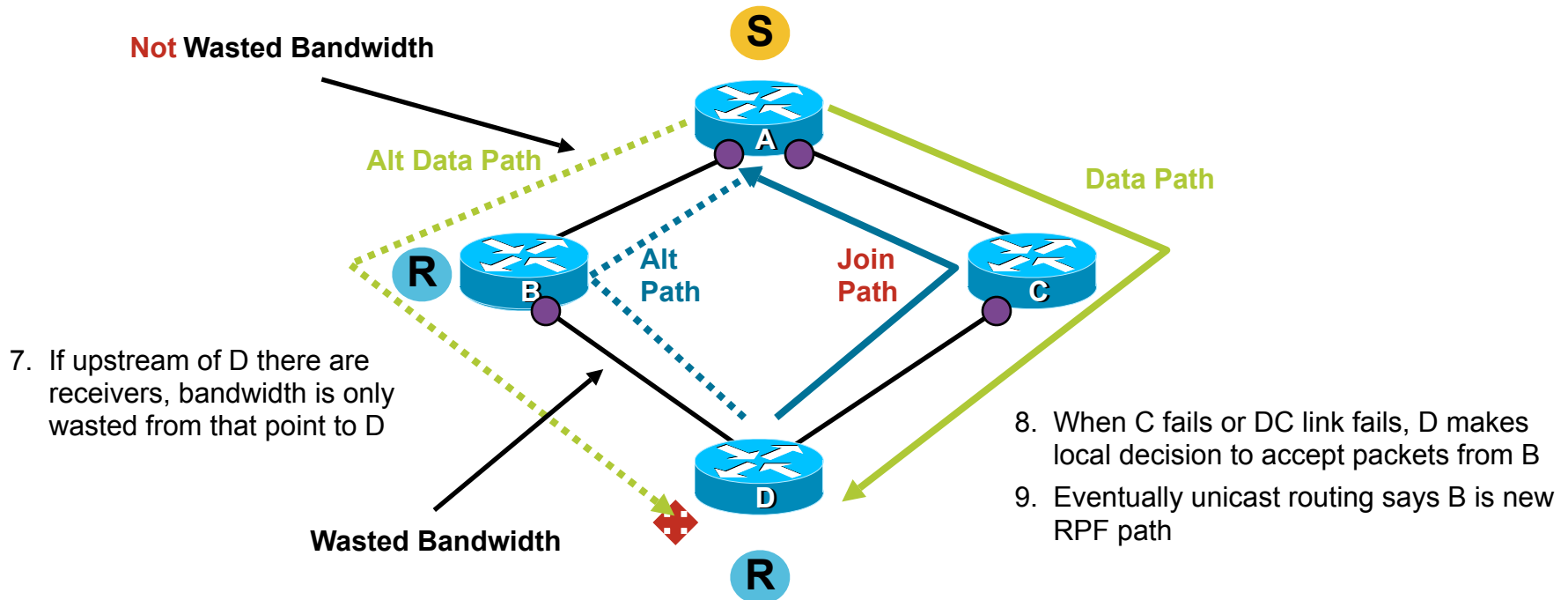

7. If upstream of D there are receivers, bandwidth is only wasted from that point to D

8. When C fails or DC link fails, D makes local decision to accept packets from B
 9. Eventually unicast routing says B is new RPF path

1. D has ECMP path {BA, CA} to S
2. D sends join on RPF path through C
3. D can send alternate-join on BA path
4. A has 2 oifs leading to a single receiver
5. When RPF path is up, duplicates come to D
6. But D RPF fails on packets from B

- Data Path
- rpf Path (RPF Join)
- Alt Join (Sent on Non-rpf)
- Interface in oif-list
- Link Down or RPF-Failed Packet Drop

Concept Example

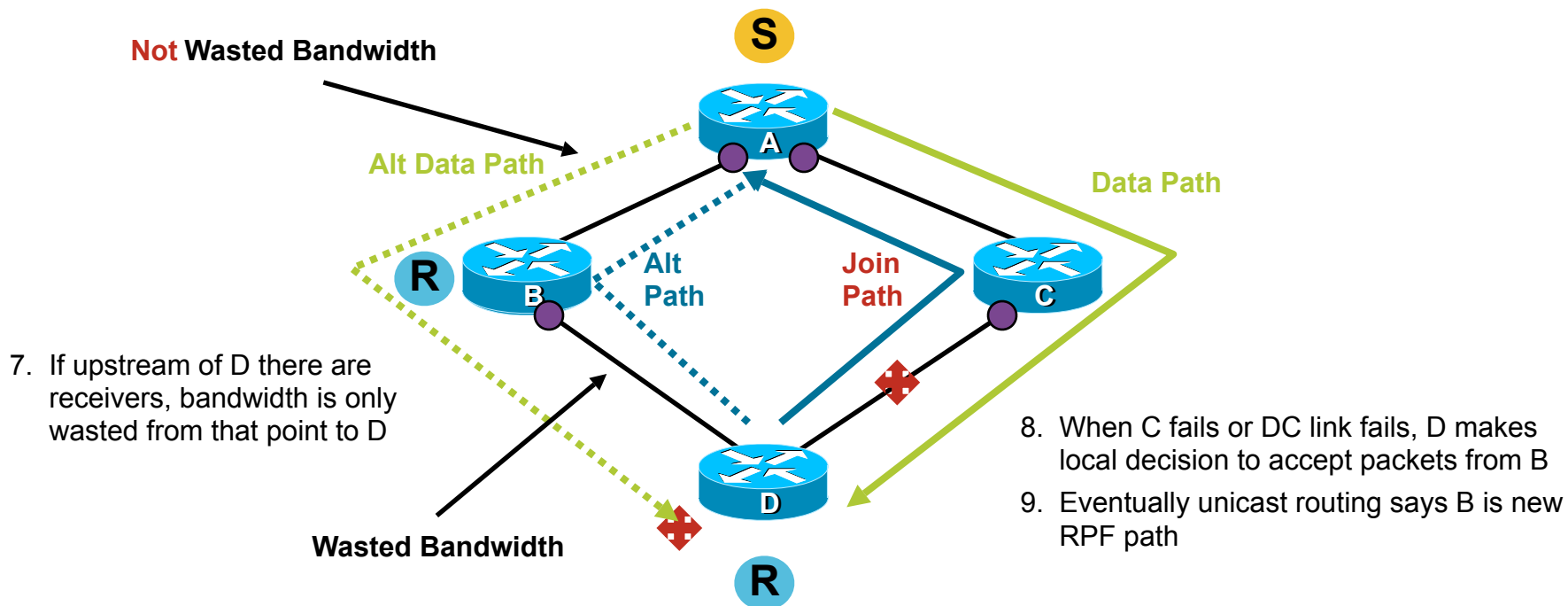

7. If upstream of D there are receivers, bandwidth is only wasted from that point to D

8. When C fails or DC link fails, D makes local decision to accept packets from B
 9. Eventually unicast routing says B is new RPF path

1. D has ECMP path {BA, CA} to S
2. D sends join on RPF path through C
3. D can send alternate-join on BA path
4. A has 2 oifs leading to a single receiver
5. When RPF path is up, duplicates come to D
6. But D RPF fails on packets from B

- Data Path
- rpf Path (RPF Join)
- Alt Join (Sent on Non-rpf)
- Interface in oif-list
- Link Down or RPF-Failed Packet Drop

Concept Example

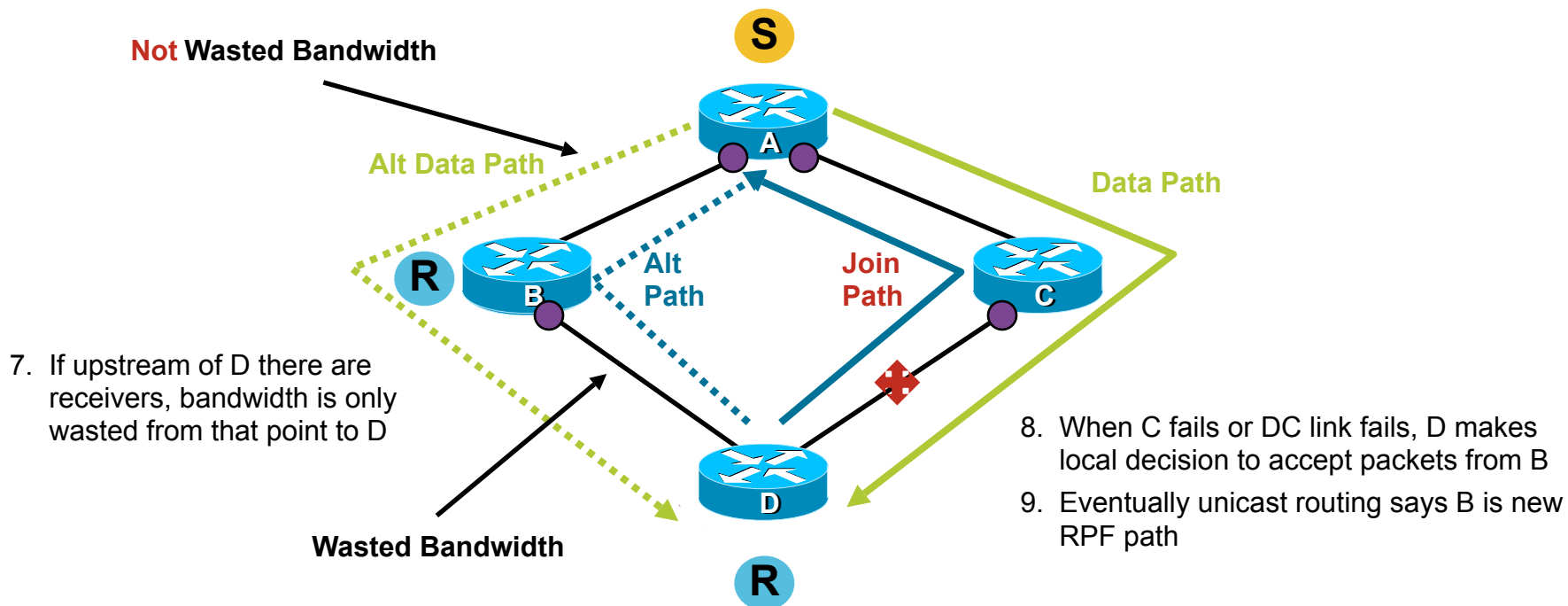

7. If upstream of D there are receivers, bandwidth is only wasted from that point to D

8. When C fails or DC link fails, D makes local decision to accept packets from B
 9. Eventually unicast routing says B is new RPF path

1. D has ECMP path {BA, CA} to S
2. D sends join on RPF path through C
3. D can send alternate-join on BA path
4. A has 2 oifs leading to a single receiver
5. When RPF path is up, duplicates come to D
6. But D RPF fails on packets from B

- Data Path
- rpf Path (RPF Join)
- Alt Join (Sent on Non-rpf)
- Interface in oif-list
- Link Down or RPF-Failed Packet Drop

Monitoring solutions



Monitoring a Video Transport Service

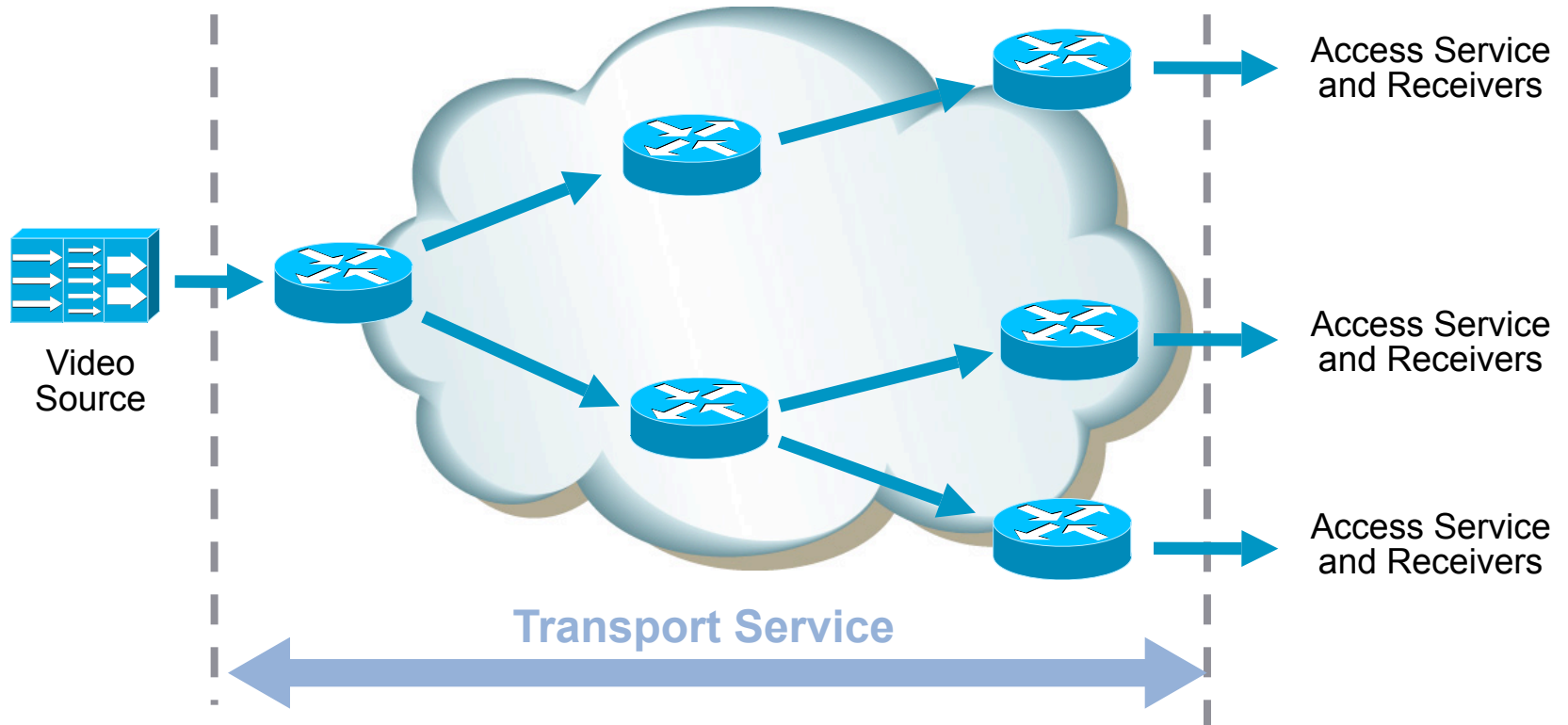

- Transport service provider must ensure proper service from source boundary to receiver or access service boundaries

MDI (RFC 4445)

- Media Delivery Index (MDI) is a combined index based on the following 2 metrics
- Media Loss Rate (MLR)
 - Monitor RTP or encapsulation protocol with a flow sequence numbers
 - Monitor continuity counter in MPEG-2 Transport Stream
 - Determines media packet loss per second
- Delay Factor (DF)
 - Amount of buffer required to transport the jittered packets without loss

Interpreting MDI Metrics

- DF is high but MLR is 0
 - Significant packet jitter is present on the network but packets have not been lost up to the measurement point.
 - May result in downstream buffer overflows that will result in packet loss or underflows that result in decoder macro blocking.
- DF is low but MLR indicates packet loss
 - MPEG Transport Stream may be corrupted.
- MLR indicates packet loss and DF is high
 - Packets are likely being lost in the network path.
 - Tracking MDI through strategic network locations will indicate the source of the loss.
- Do keep in mind CBR vs. VBR when dealing with DF

Video probe

IP-Probe

Main Alarms Mon MDI RDP Ethernet ETR 290 ASI COFDM FSM Setup Data About

Parameters

Joined multicasts

Current measurements

i	Name	Signal	Net bitrate	Curr bitrate	Min bitrate	Max bitrate	CC errs	Pids	Dst address	TOS	TTL	Src address	Mapping	RTP dr
i	BBC ONE (DCM1/3/3)	33m	5.87 Mbps	10.09 Mbps	10.08 Mbps	10.10 Mbps	0	12	239.232.0.111:3000	128	62	192.168.173.2:49152	7TS/rtp	0
i	BBC TWO (DCM1/3/3)	33m	5.12 Mbps	10.09 Mbps	10.08 Mbps	10.10 Mbps	0	12	239.232.0.112:3000	128	62	192.168.173.2:49152	7TS/rtp	0
i	BBC N24 (DCM1/3/3)	33m	4.57 Mbps	10.10 Mbps	10.08 Mbps	10.10 Mbps	0	12	239.232.0.113:3000	128	62	192.168.173.2:49152	7TS/rtp	0
i	BBC HD (DCM1/3/3)[D]	33m	19.33 Mbps	19.98 Mbps	19.97 Mbps	19.99 Mbps	0	19	239.232.0.114:3000	128	62	192.168.173.2:49152	7TS/rtp	0
i	HD5 (DCM1/3/3)	33m	9.38 Mbps	14.13 Mbps	14.11 Mbps	14.14 Mbps	0	9	239.232.0.115:3000	128	62	192.168.173.2:49152	7TS/rtp	0
i	ITV 1 (DCM1/3/3)	33m	4.27 Mbps	10.09 Mbps	10.07 Mbps	10.10 Mbps	0	13	239.232.0.116:3000	128	62	192.168.173.2:49152	7TS/rtp	0
i	ITV 2 (DCM1/3/3)	33m	3.39 Mbps	10.09 Mbps	10.07 Mbps	10.10 Mbps	0	13	239.232.0.117:3000	128	62	192.168.173.2:49152	7TS/rtp	0
i	ITV 3 (DCM1/3/3)	33m	3.58 Mbps	10.09 Mbps	10.07 Mbps	10.10 Mbps	0	13	239.232.0.118:3000	128	62	192.168.173.2:49152	7TS/rtp	0
i	ITV 4 (DCM1/3/3)	33m	3.77 Mbps	10.09 Mbps	10.08 Mbps	10.10 Mbps	0	12	239.232.0.119:3000	128	62	192.168.173.2:49152	7TS/rtp	0
i	BBC 3 (DCM1/3/3)	33m	1.13 Mbps	10.09 Mbps	10.08 Mbps	10.10 Mbps	0	10	239.232.0.120:3000	128	62	192.168.173.2:49152	7TS/rtp	0

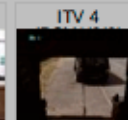

Video probe

Inter Arrival Time histogram

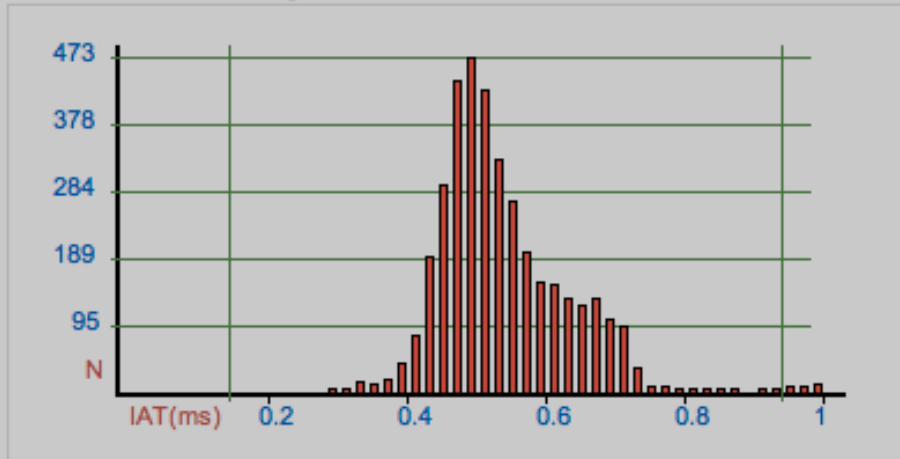

Detected TS components

Service [sid]	PIDs (scr)	Bitrate	Min bitr	Max bitr	CC errs
BBC HD [6940]	19 (0)	19.330	19.294	19.346	0
Other PIDs	4 (0)	0.475	0.461	0.498	0

Multicast statistics

Name	Signal	Net bitrate	Curr bitrate	Min bitrate	Max bitrate	CC errs	Pids	Dst address	TOS	TTL	VLAN ID	Src a
BBC HD (DCM1/3/3)[D]	32m	19.34 Mbps	19.98 Mbps	19.97 Mbps	19.99 Mbps	0	19	239.232.0.114:3000	128	62	-	192.



Close

IAT auto

IAT 1ms

IAT 5ms

IAT 25ms

IAT 100ms

DVB Forum TR 101 290 (MPEG-2 TS) 1st Priority Parameters

- Basic set of parameters which are considered necessary to ensure that the TS can be decoded.

Transport Stream Sync Loss – Occurrences of stream synchronization loss

Sync Byte Error – Synch byte not sent after specified number of bytes

PAT Error – Program Association Table was not sent on schedule

PAT Error 2 – Program Association Table extras were not sent on schedule

Continuity Error – Lost or misordered packet in transport stream

PMT Error – Program Map Table was not sent on schedule

PID Error – Program ID not sent on schedule

DVB Forum TR 101 290 (MPEG-2 TS) 2nd Priority Parameters

- Additional parameters which are recommended for continuous monitoring.

Transport Error – Transport header indicated an error

CRC Error – Numbers of errors observed while sending Program ID tables

PCR Error – Loss of Program Clock Rate (PCR) for more than 100 milliseconds

PCR Repetition Error – PCR indicator not sent within 40 milliseconds

PCR Discontinuity Indicator Error – PCR rate variations above specified value

PCR Accuracy Error – PCR variation out of range – constant bite rate only

PMT Error 2 – Program Map Table extras were not sent on schedule

PTS Error – Presentation Time Stamp Repetition period exceeded 700 milliseconds

CAT Error – Conditional Access (CA) Table not sent on schedule

Video probe (ETR 290)

IP-Probe

Main Alarms Mon MDI RDP Ethernet **ETR 290** ASI FSM Setup Data About

ETR Overview **ETR Details** Services Bitrates PSI/SI/PSIP PID list PCR ETR thresh. PID thre

Ethernet ASI **ASI Input 0** ASI 

Priority 1	Priority 2	Priority 3	Other checks
<input checked="" type="checkbox"/> TS Sync (0 / 1)	<input checked="" type="checkbox"/> Transport	<input checked="" type="checkbox"/> NIT (1 / 1)	<input type="checkbox"/> CA System
<input checked="" type="checkbox"/> Sync byte	<input checked="" type="checkbox"/> CRC	<input checked="" type="checkbox"/> SI Rep Rate (0 / 502)	<input checked="" type="checkbox"/> Pid checks
<input checked="" type="checkbox"/> PAT (0 / 146)	<input checked="" type="checkbox"/> PCR	<input type="checkbox"/> Buffer	<input checked="" type="checkbox"/> Service checks
<input checked="" type="checkbox"/> Continuity	<input checked="" type="checkbox"/> PCR Accuracy	<input checked="" type="checkbox"/> Unref PID	<input checked="" type="checkbox"/> Interface checks
<input checked="" type="checkbox"/> PMT (0 / 139)	<input checked="" type="checkbox"/> PTS	<input checked="" type="checkbox"/> SDT (0 / 65)	
<input checked="" type="checkbox"/> Missing PID (0 / 7)	<input checked="" type="checkbox"/> CAT (0 / 152)	<input checked="" type="checkbox"/> EIT (1 / 1)	
		<input checked="" type="checkbox"/> RST	
		<input checked="" type="checkbox"/> TDT (1 / 1)	

Show additional measurements

Quality of Experience (QoE)

- Perceptual quality analysis
 - As perceived by the end-user
- Availability of the IPTV Channel/Service
- Measurement of the channel change time (zapping)
- Video quality metrics
 - PSNR
 - Blockiness
 - Jerkiness
 - Blurriness
- Audio

Video QoE probe

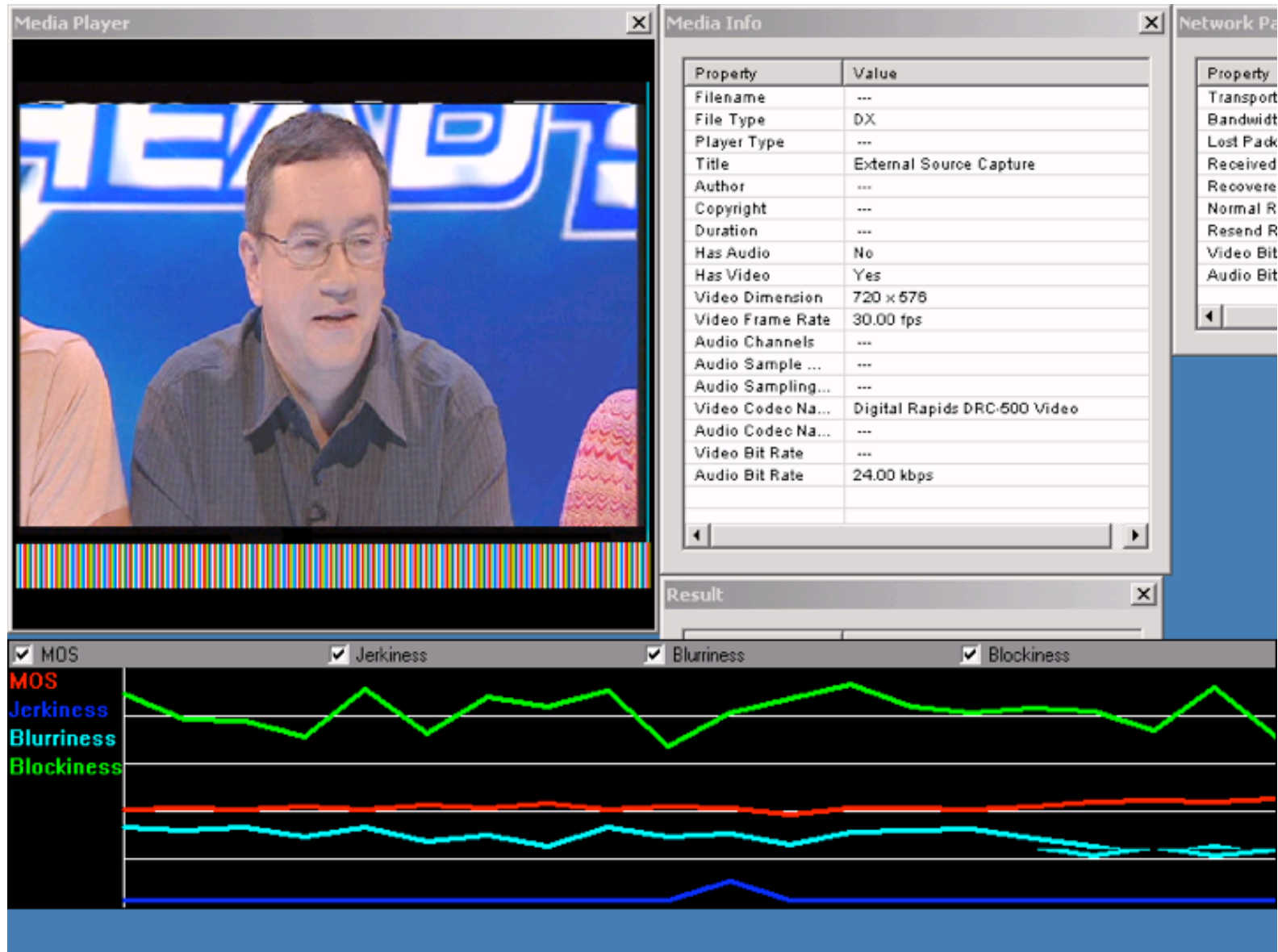

Summary



Not all video services are equal...

- Plan your network architecture
 - QoS, hardware capabilities, multicast, ...
 - FC, MoFRR, AL-FEC, live-live, ...
- Plan your services architecture
 - Compressed != frame by frame compressed != Uncompressed
 - IPTV or cable distribution vs. contribution between broadcasters
- Plan your monitoring strategy
 - Distribute the probes to match the flow paths
 - Distribute and layer the monitoring services
 - Check IP packets, service payload headers & decoded services

