

SwiNOG-11

Broadband access over Cable (Update)

Michel Renfer
LAN Services AG
michel.renfer@lan.ch

20. Oct. 2005



Broadband market today ...

10. Oktober 2005

Bern (AWP/sda) - Liberty Global, die neuen Besitzerin des Schweizer Kabelnetzbetreibers Cablecom Holdings AG, hat grosse Pläne: "Wir machen die Schweiz schneller", sagte der Liberty-Topmanager Gene Musselman in einem Interview mit der "SonntagsZeitung".

"Internet ist in der Schweiz langsam. Das werden wir ändern", kündigte Musselman an. Er schliesst nicht aus, dass mittelfristig mit einem Tempo von **100 Megabits** pro Sekunde gesurft werden könne. Derzeit gingen die meisten Cablecom-Kunden noch mit einem Tempo von 600 Kilobits bis 1 Megabit online.

Grosse Pläne hegt Musselmann auch für das digitale Fernsehen, das Cablecom 1999 lanciert hatte. Der Marktanteil sei "noch nicht signifikant". Liberty wolle nun investieren, um das Netz weiter auszubauen und neue Services in die Schweiz zu bringen. Dieser Tage fänden die Budget-Verhandlungen mit der Cablecom statt.

Mit diesen Ankündigungen reagierte Musselman auf Kritik, dass Liberty Unternehmen kaufe, um sie so rasch als möglich wieder abzustossen: "Wir kaufen nicht, um ein Unternehmen zu melken und nach einigen Jahren wieder abzustossen. Wir kaufen, um langfristig zu investieren, neue Dienstleistungen einzuführen und zu wachsen."

"Wir wollen auch in der Schweiz ein verantwortungsbewusster, verlässlicher Anbieter sein", sagte Musselman. Nicht zuletzt mit tiefen Preisen wolle er die Konkurrentin Swisscom "künftig viel stärker herausfordern".

Musselman ist seit 2003 Präsident und operativer Chef (COO) von UPC Broadband, der grössten Division von Liberty Global. Er beaufsichtigt die europäischen Kabelnetztöchter. Liberty hatte die Cablecom für 2,8 Mrd CHF gekauft. Der geplante Börsengang wurde in letzter Minute abgesagt.

Broadband market today ...

But how would we transport the 100 MBit/s to the customer?



DOCSIS – RF spectrum

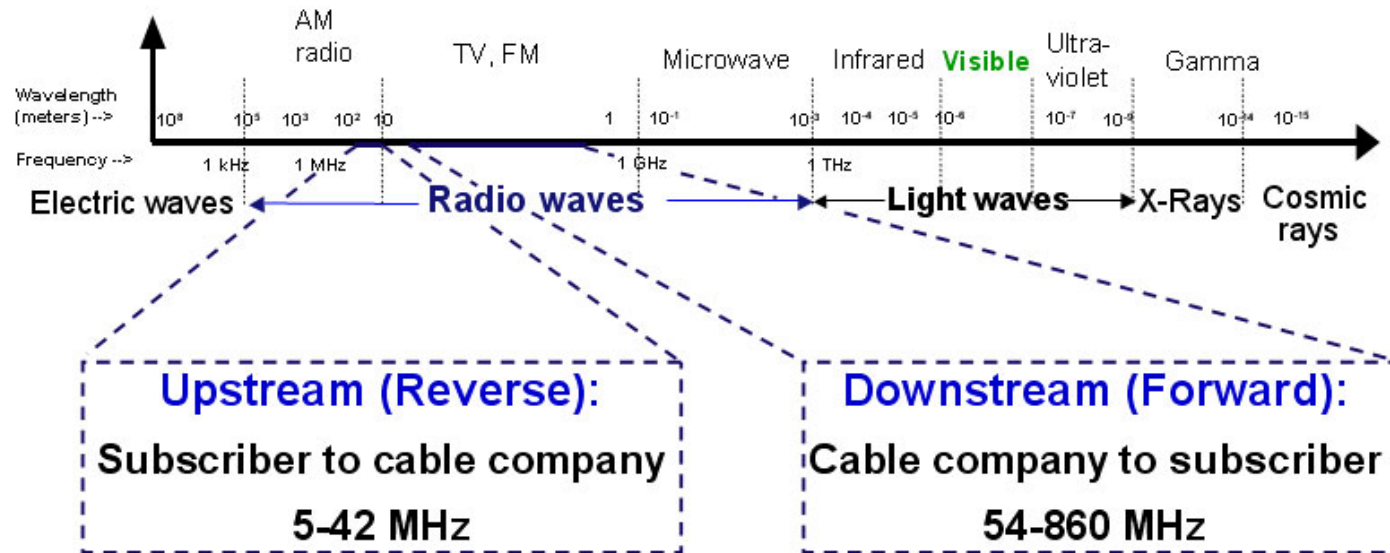

DOCSIS – CMTS to fibre node connectivity

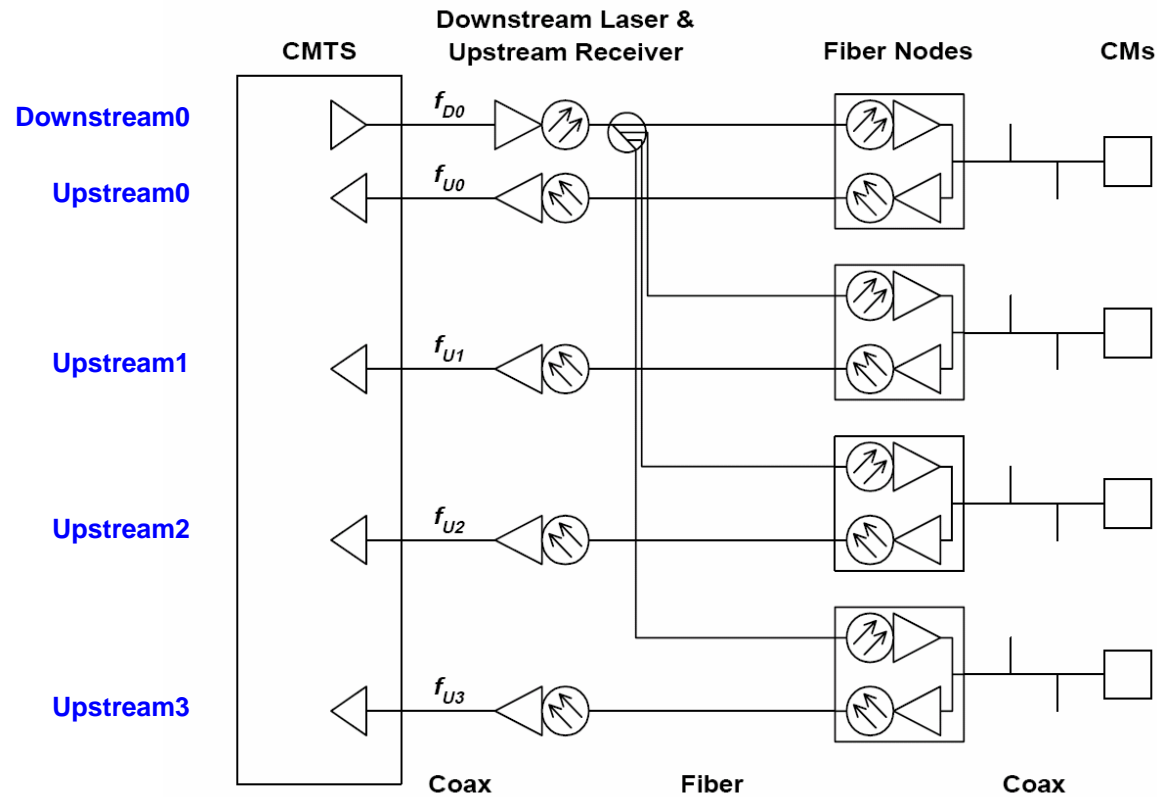

- Example based on one-to-one connectivity between nodes and cmts ports
- Key parameters: households per node / nodes per upstream / number of downstreams

DOCSIS – Modulation modes

Downstream

- 64 QAM, 256 QAM

Upstream

- QPSK, 8 QAM*, 16 QAM, 32 QAM*, 64 QAM*

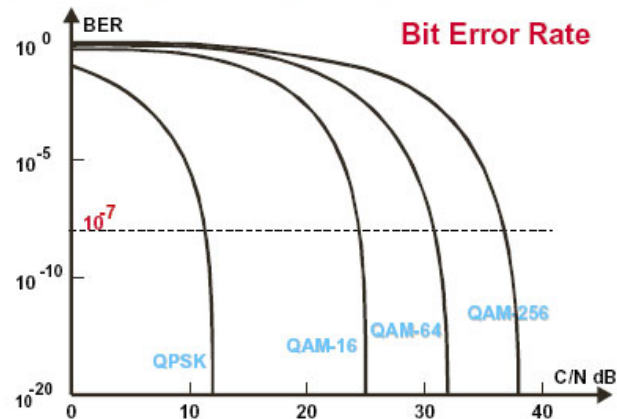

*) only DOCSIS 2.0 upstream channels

Modulation modes vs bitrates

Downstream

<u>Modulation mode</u>	<u>Raw bitrate</u>
64 QAM	30 Mbit/s
256 QAM	43 Mbit/s

Upstream

<u>Modulation mode</u>	<u>Raw bitrate 3.2 MHz</u>	<u>Raw bitrate 6.4 MHz</u>
QPSK	5.12 Mbit/s	10.30 Mbit/s
8 QAM *)	7.68 Mbit/s	15.45 Mbit/s
16 QAM	10.30 Mbit/s	20.64 Mbit/s
32 QAM *)	12.90 Mbit/s	25.80 Mbit/s
64 QAM *)	15.48 Mbit/s	30.96 Mbit/s

*) only DOCSIS 2.0 upstream channels

Changes between 2001 and today

The toys for the children became larger... :-P



Changes between 2001 and today

- Most network increased their number of fibre nodes
- Most network decreased their number of households per fibre node
- New linecards have nice features to actively improve the transmission quality
- New linecards allows us to replace QPSK with 16 QAM without modifications
- Traffic volume are significantly higher than 2001
- New services demand for high capacity (VoD) and stability (VoC)

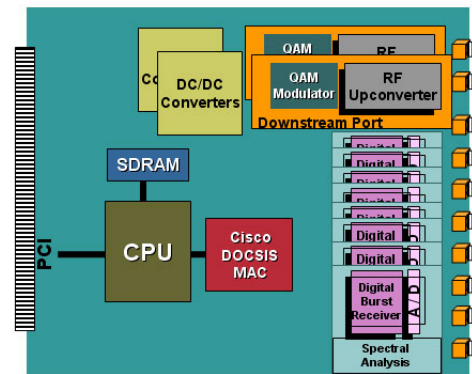

Example: Cisco MC28U Broadband Processing Engine

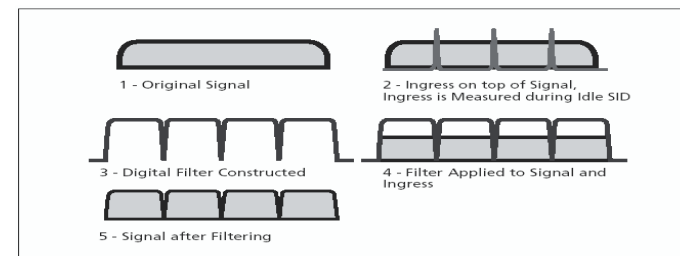

Example: Ingress noise cancellation feature

Bandwidth calculations

A real world example

Service	Channels	Digital bandwidth*	Capacity
TV (analog)	53	x 3.75 Mbit/s	198.75 Mbit/s
TV (digital)	2	x 38 Mbit/s	76 Mbit/s
DOCSIS	1	x 38 Mbit/s	38 Mbit/s
Used today	56		312.75 Mbit/s
Potential **)	98	x 38 Mbit/s	3724 Mbit/s

*) Payload rate

**) 860 MHz network with 98x 8 MHz DS channels

DOCSIS Specification history

DOCSIS 1.0

The original specification was released Dec 1997.

The Cisco uBR7200 shipped 9 months later in Sept 1998.

1.0 is considered a best effort data service. The majority of the installations are still 1.0

DOCSIS 1.1

Released March 1999

Introduced QOS. Intended for VoIP and tiered data services

DOCSIS 2.0

Introduced Dec 2001

Introduced ATDMA and SCDMA Advanced PHYs for the upstream

DOCSIS 3.0 / Wideband

Finalized mid 2006

Will bring significantly more Downstream Bandwidth at lower costs

Wideband DOCSIS

WIDEBAND

DOCSIS 3.0



M-CMTS

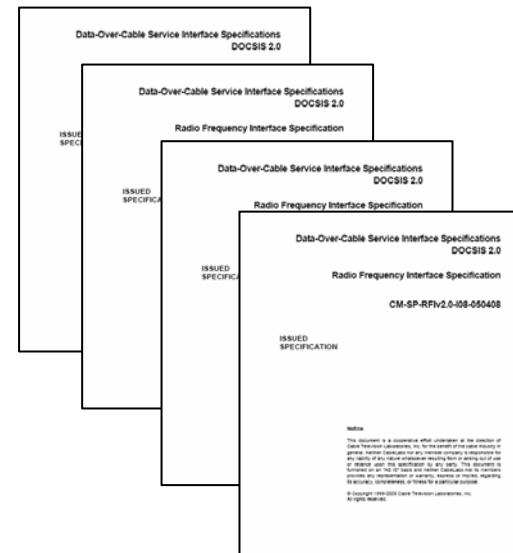

Wideband DOCSIS

Expand the cable spectrum bandwidth

- Reorganize the bits into more efficient bundles

- Create a much bigger, fatter pipe

Reuse existing network elements

- Leverage the Cable IP network infrastructure

- Share the DOCSIS provisioning & control plane

- Piggyback on existing VOD edge QAM technology

Achieve the lowest cost per bit

- Take advantage of Ethernet cost curves

- Use existing silicon & product architectures

Basic Concept of Wideband
“10x the bandwidth at 1/10 the cost”

The wideband protocol does just that ...

Traditional DOCSIS Downstream Channel



Single QAM

Wideband Downstream Channel

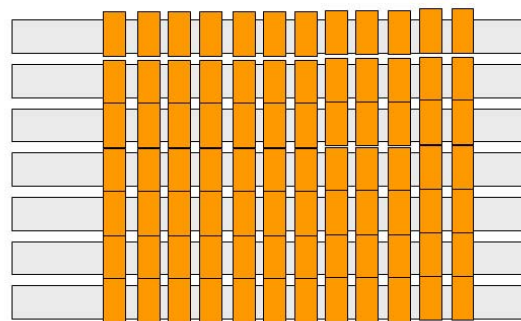

n Multiple QAMs

Wideband architecture on existing deployments

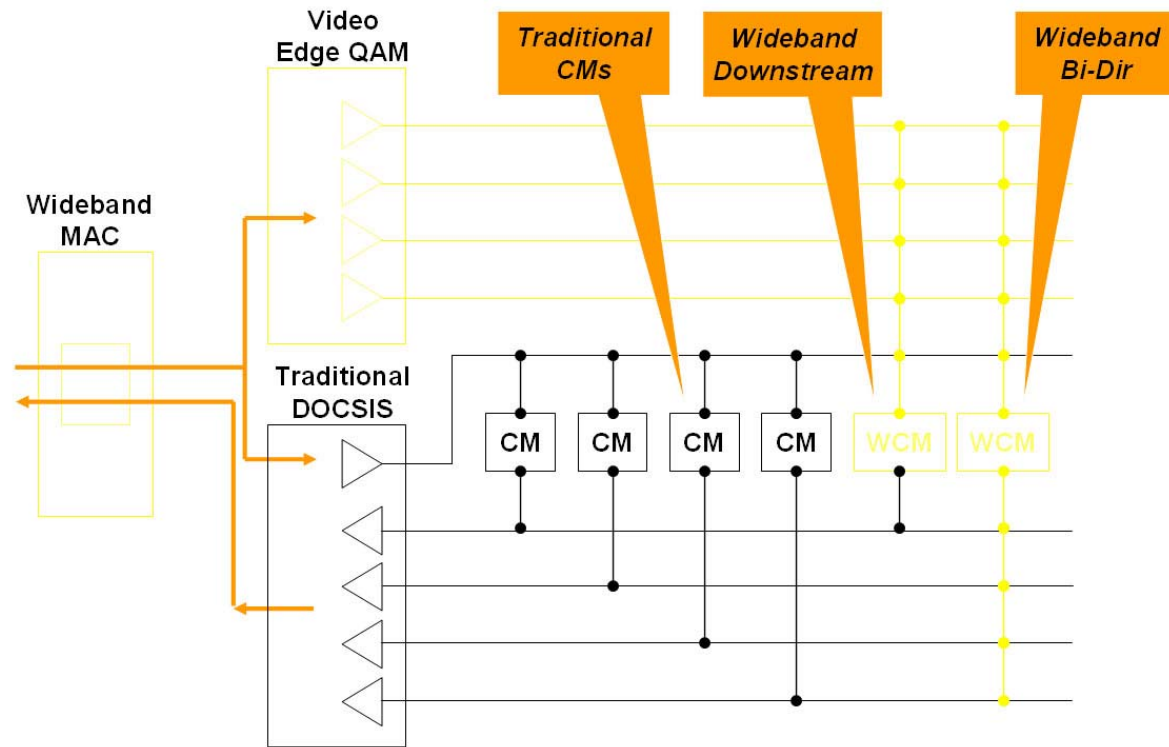

CableLab's M-CMTS reference architecture

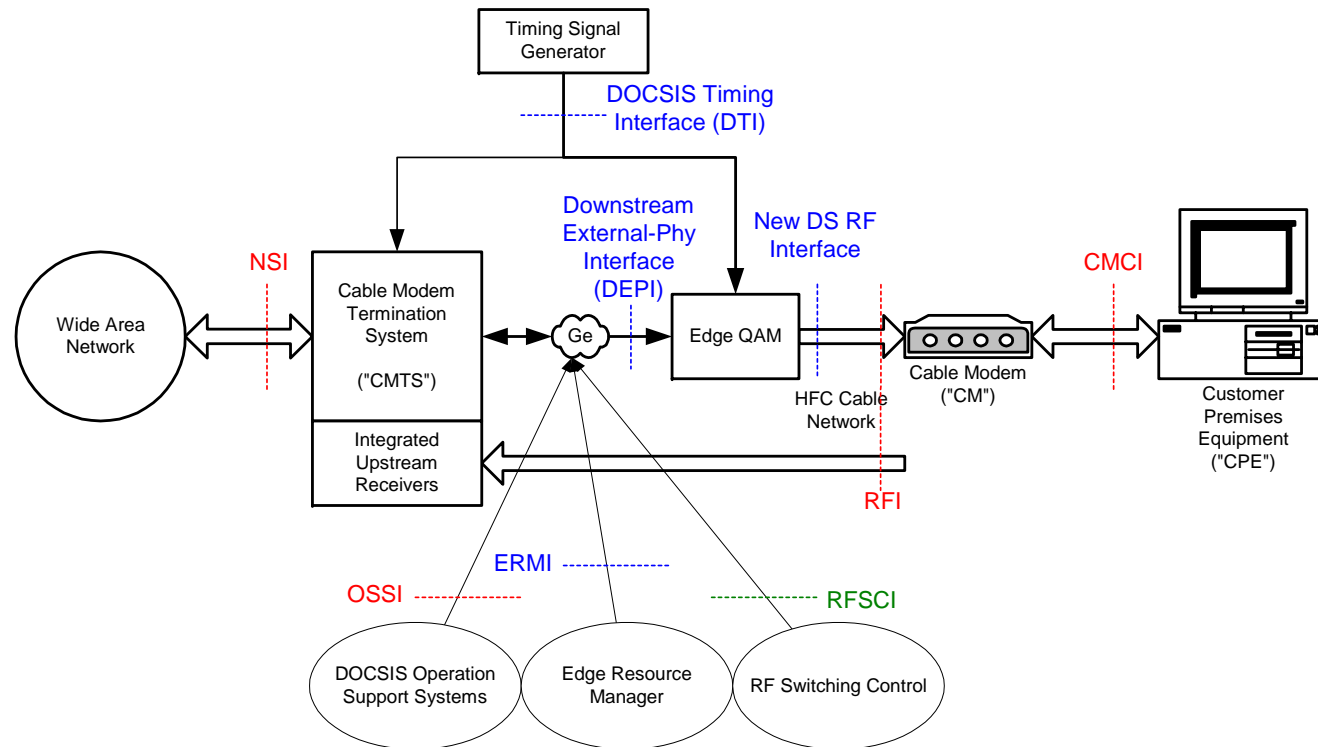

Cablelab's specification timeline

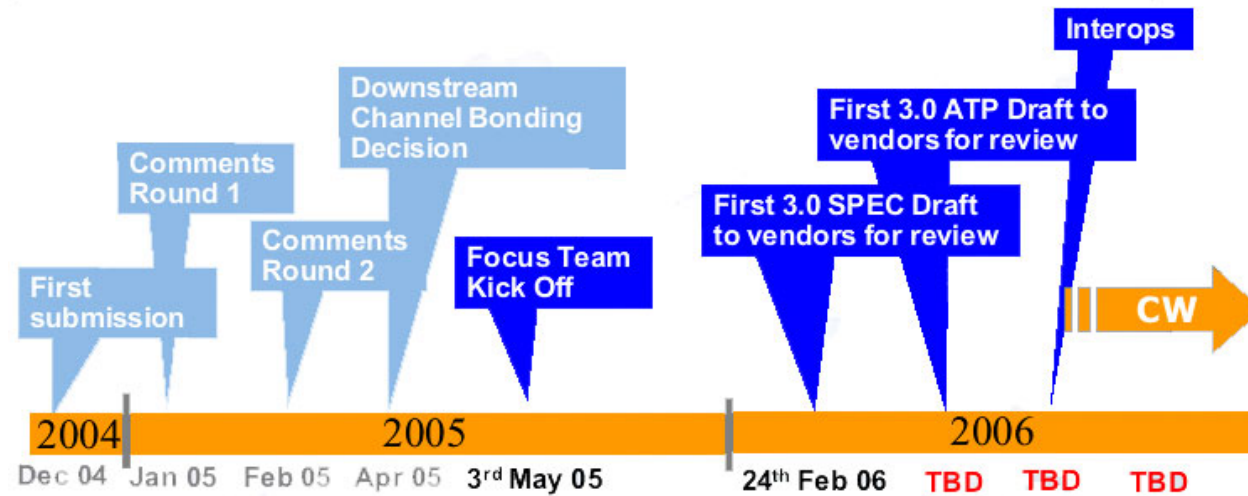

- First selected field trials of Wideband in Q4 2005
- Wideband CMs with 3.0-ready hardware available in Q1/2 2006
- Wideband available on the complete cisco uBR platform in Q3/4 2006
- Full M-CMTS architecture expected for 2007

References

- <http://www.lan.ch>
- <http://www.quickline.com>
- <http://www.cisco.com/go/cable>
- <http://www.cablelabs.com>